

CLAMPEX[®]

Shaft-Hub-Connection

Table of contents

Page

Brief information **209**

Selection and calculation **234-235**

CLAMPEX®-Selection

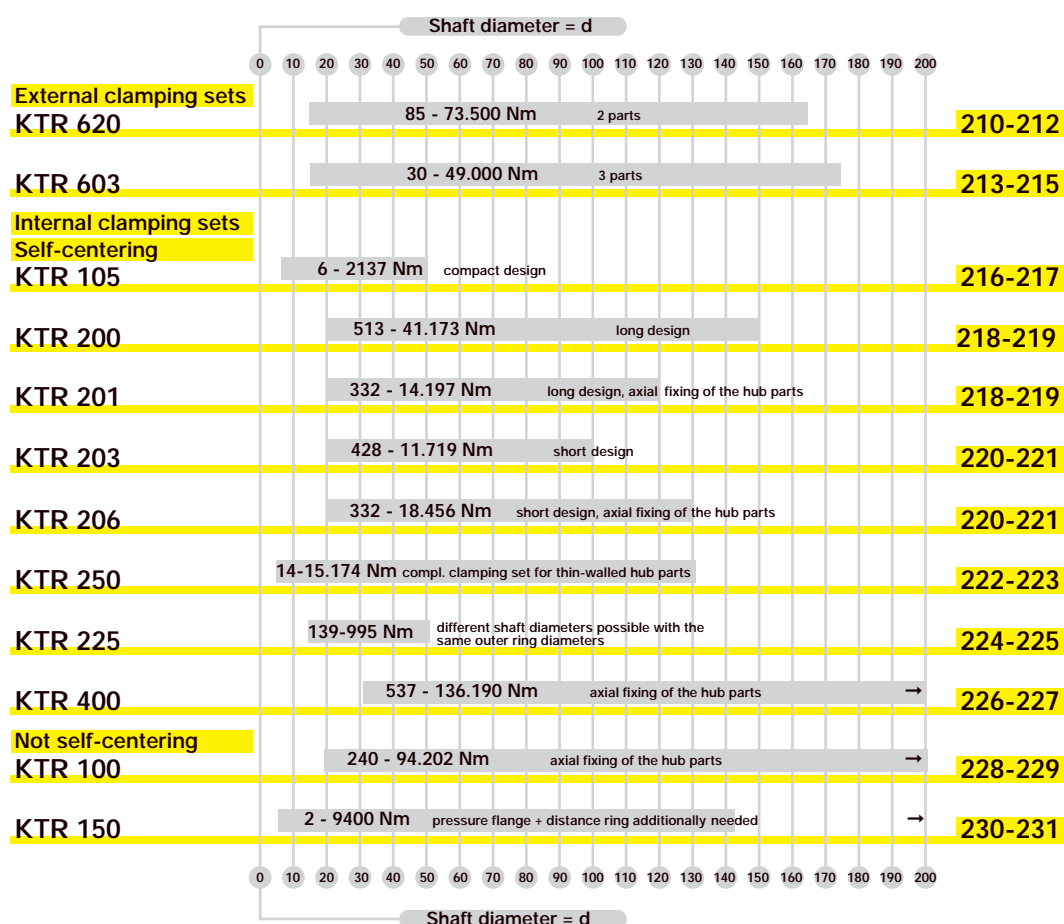

CLAMPEX®-lines on request

KTR 401 **233**

KTR 125 and KTR 125.1 **233**

KTR 700 Rigid shaft coupling **233**

SPH clamping sleeve **233**

Reduction of costs! Reduction of components! Reduction of dimensions!

Factors like cost reduction, material saving, simplified production processes, shorter delivery times of material are already determined by designing and development. Anyway, the growing demands can no longer be satisfied by keyway connections.

In this case the use of **CLAMPEX® clamping elements** offers new possibilities as a shaft-hub-connection:

- Material saving by smaller shaft and hub dimensions
- Simplified production processes
- Suitable for modern drive systems
- Easy assembly and disassembly with standard tools
- Ideal for drives with high vibratory loads, e. g. acceleration and braking
- Produce connections that are permanently free from destruction, i. e. no shearing off of keyways, dowel pins, pins, etc.
- Specifically suitable for high-speed drives
- Insensitive to dirt
- Reusable repeatedly
- Overload protection of the machine components by slipping
(Repeated slipping should be avoided)
- Corrosion- and acid-resistant surface coating for food-processing industry, marine industry and chemical industry on request
- Simple calculation of the clamping connection

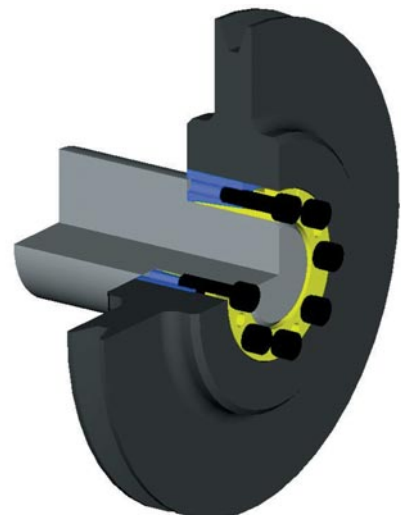
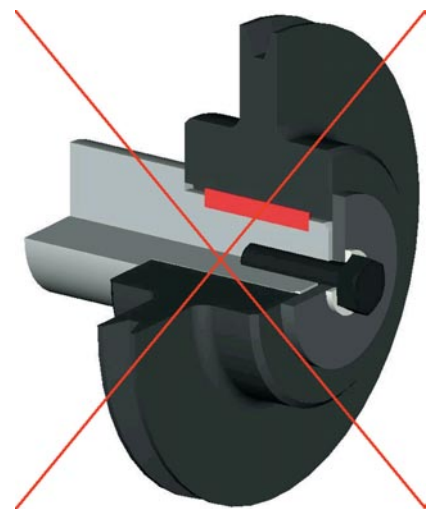

Advice for selection:

The transmission data mentioned in the catalogue are parameters found out by calculations. Subject to tests and the physical coefficient of friction slight deviations from the transmission values may arise.

Copyright according to DIN 34

We reserve the right for modifications of dimensions and designs.

KTR 620



- Applications on hollow shafts, slip-on gears, couplings, mechanical shrink connections
- Suitable for high torque loads
- Easy assembly by optical mounting groove
- Corrosion-resistant outer ring (phosphatized)
- Good centering and concentricity characteristics
- Please find our detailed mounting instructions on our homepage (www.ktr.com)

Outer ring
phosphatized
and conus
contact
surfaces
greased

Inner ring

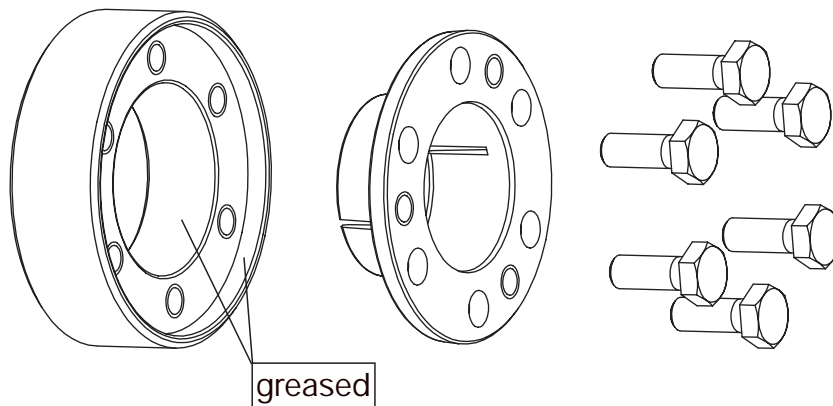

Assembly

Clean and degrease the contact surfaces of shaft and hub (internal hollow shaft). Slightly unscrew the clamping screws and put the clamping set externally onto the hub/hollow shaft. Before tightening the clamping screws please assemble the shaft. Evenly tighten the diametrically opposite clamping screws until the front surfaces of the outer and inner rings are flush. The max. screw tightening torque indicated must not be exceeded. The values for T and F_{ax} indicated in the table relate to an assembly with greased external clamping set. The external clamping sets are delivered in greased condition. When assembling grease-free external clamping sets the values shown in the table and the values calculated are different. In case of questions, please feel free to contact us.

Note: Contact surfaces of shaft and hub bore (internal hollow shaft) must not be greased or oiled.

Disassembly

All clamping screws must be unscrewed evenly and successively. Do not completely unscrew the clamping screws off the thread. Loosen the external taper ring in the inner ring with the forcing thread.

Tolerances, surfaces

One accurate turning process is sufficient:
 $R_z \leq 16\mu\text{m}$

Maximum permissible tolerances:
d= f7 for the hub (external hollow shaft)

$d_w = h6/H7$
 $d_w > \varnothing 160 - g6/H7$

Axial movement

KTR 620: During the tightening of the screws there is no axial movement of the hub towards the shaft.

Orderform:

KTR 620	20	x	47
Type:	Size of inside diameter		Size of outside diameter

CLAMPEX® - Shaft-Hub-Connection

Technical data

KTR 620

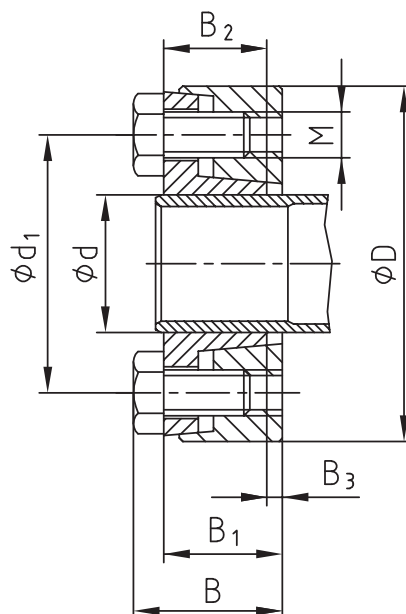

Frictionally engaged connection of a DATAFLEX® torque measuring shaft with KTR 620

d x D [mm]	Shaft diameter dw [mm]	Transmittable torque or axial force		Dimensions [mm]					Clamping screws DIN 933 - 10.9 $\mu_{total}=0,14$			Forcing thread		Surface pressure clamping set / hollow shaft P_h [N/mm ²]	Weight -kg
		T [Nm]	F _{ax} [kN]	B	B ₁	B ₂	B ₃	d1	M	z	T _a [Nm]	z ₁	M ₁		
16 x 41	13	85	13	19	15	13	2	28	M6	3	12	2	M6	281	0,15
	14	105	15												
20 x 47	17	155	18	19	15	13	2	32	M6	4	12	2	M6	288	0,17
	18	175	19												
24 x 50	20	235	24	22	18	16	2	36	M6	5	12	2	M6	266	0,25
	22	305	28												
30 x 60	24	390	33	24	20	18	2	44	M6	6	12	3	M6	256	0,30
	25	430	34												
36 x 72	27	510	38	27,5	22	20	2	52	M8	5	30	2	M8	256	0,49
	30	690	46											253	
38 x 72	33	820	50	29,5	24	22	2	61	M8	6	30	2	M8	254	0,61
	34	910	54											231	
40 x 80	35	850	49	29,5	24	22	2	61	M8	6	30	2	M8	254	0,61
	37	980	53											231	
44 x 80	38	1180	62	31,5	26	23,5	2,5	68	M8	8	30	2	M8	249	0,84
	40	1320	66												
50 x 90	42	1470	70	31,5	26	23,5	2,5	68	M8	8	30	2	M8	249	0,84
	40	1320	66												
55 x 100	42	1400	67	34,5	29	26	3	72	M8	8	30	2	M8	223	1,20
	45	1650	73												
60 x 110	48	1700	71	34,5	29	26	3	80	M8	9	30	3	M8	223	1,50
	50	2050	82											216	
62 x 110	52	2200	85	34,5	29	26	3	80	M8	9	30	3	M8	216	1,50
	50	2050	82												
68 x 115	50	1900	76	34,5	29	26	3	86	M8	9	30	3	M8	222	1,60
	55	2450	89												
75 x 138	60	3250	108	38	31	27	4	100	M10	10	59	2	M10	227	2,60
	65	3850	118												
80 x 141	60	3350	112	38	31	27	4	104	M10	10	59	2	M10	224	2,80
	65	3980	122												
80 x 141	70	4620	132	38	31	27	4	104	M10	10	59	2	M10	224	2,80
	65	3980	122												

All clamping sets available from stock.

Other sizes on request.

Inner ring slotted up to size 40x80, all sizes of outer ring phosphated.

CLAMPEX[®] - Shaft-Hub-Connection

Technical data

KTR 620



Frictionally engaged connection of a DATAFLEX[®] torque measuring shaft with KTR 620

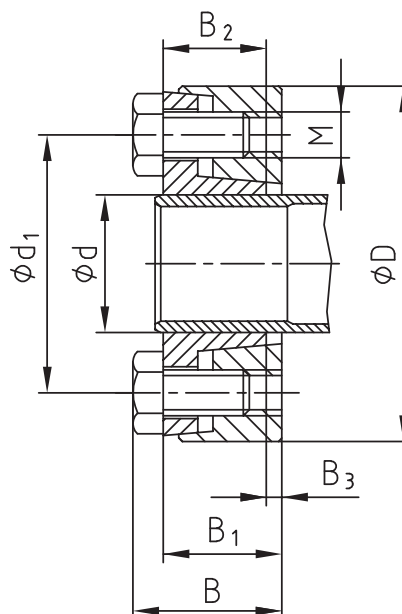

d x D [mm]	Shaft diameter dw [mm]	Transmittable torque or axial force		Dimensions [mm]					Clamping screws DIN 933 - 10.9 $\mu_{total}=0,14$			Forcing thread		Surface pressure clamping set / hollow shaft P_h [N/mm ²]	Weight -kg
		T [Nm]	F _{ax} [kN]	B	B ₁	B ₂	B ₃	d1	M	z	T _a [Nm]	z ₁	M ₁		
90 x 155	65	5200	160	45	38	34	4	114	M10	11	59	2	M10	219	3,40
	70	6000	171												
	75	6900	184												
100 x 170	70	6600	189	50	43	39	4	124	M10	14	59	3	M10	206	4,60
	75	7600	203												
	80	8600	215												
110 x 185	80	10600	265	57	49	44	5	136	M12	12	100	4	M12	212	6,20
	85	11900	280												
	90	13300	296												
120 x 197	85	12700	299	61	53	48	5	147	M12	14	100	4	M12	205	7,40
	90	14200	316												
	95	15700	331												
125 x 215	90	14600	324	61	53	48	5	158	M12	14	100	4	M12	215	9,30
	95	16000	337												
	100	17500	350												
130 x 230	95	18600	392	67	58	52	6	165	M14	12	160	4	M14	225	11,90
	100	20300	406												
	110	23600	429												
140 x 230	100	20100	402	67	58	52	6	172	M14	12	160	4	M14	205	11,00
	105	21700	413												
	115	25150	437												
155 x 263	110	27400	498	71	62	56	6	195	M14	14	160	4	M14	212	16,00
	115	29600	515												
	125	32000	533												
165 x 290	120	41500	692	78	68	61	7	204	M16	12	250	4	M16	223	22,30
	125	44300	709												
	135	47200	726												
175 x 300	130	47600	732	78	68	61	7	214	M16	14	250	4	M16	216	23,30
	135	50500	748												
	140	53500	764												
185 x 320	140	66000	943	95	85	77	8	224	M16	16	250	4	M16	201	33,40
	145	69900	964												
	150	73500	980												

All clamping sets available from stock.

Other sizes on request.

Inner ring slotted up to size 40x80, all sizes of outer ring phosphated.

KTR 603



- „Typical external clamping set“
- For middle and high loads
- Typical applications: hollow shafts, slip-on gears
- Please find our detailed mounting instructions on our homepage (www.ktr.com)

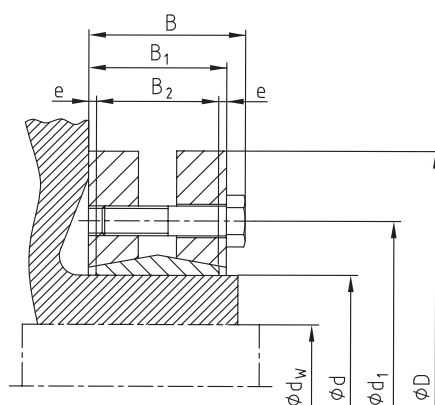

Assembly

Clean and degrease the contact surfaces of shaft and hub (hollow shaft inside). Assemble the external clamping set onto the hub (hollow shaft outside). In the area of the external clamping set the external surface of the hub (hollow shaft outside) may be lubricated. Before tightening the clamping screws, assemble the shaft or push on the hub (hollow shaft). Tighten the clamping screws by degrees and evenly one after the other until the screw tightening torque T_a mentioned in the table is achieved. Several tightening processes are necessary to achieve the requested T_a figure. The figures T and F_{ax} mentioned in the table were calculated for an assembly with oiled/greased external clamping set. The external clamping sets are delivered with oil/grease. For the assembly of external clamping sets without oil/grease the figures mentioned in the table will deviate. Please contact us for any questions you may have.

Note: Do not use any oil with molybdenum sulphide between the contact surfaces of shaft and hub bore (hollow shaft inside).

Disassembly

Unscrew all clamping screws evenly one after the other. Do not fully unscrew the screws out of the thread. Usually the clamping elements release automatically.

Tolerances, surfaces

One accurate turning process is sufficient:
 $R_z \leq 16 \mu\text{m}$

Maximum permissible tolerances:
d = h8 for the shaft

Tolerances for d_w

For d_w from 18 to 30 mm **H6 / j6**
 For d_w from 31 to 50 mm **H6 / h6**

For d_w from 51 to 80 mm **H6 / g6**
 For d_w from 81 to 500 mm **H7 / g6**

* In general bigger tolerances are possible. Please contact us!

Axial movement

KTR 603: During the tightening of the screws there is no axial movement of the hub towards the shaft

Orderform:

KTR 603	44	x	80
Type:	Size of inside diameter		Size of outside diameter

CLAMPEX® - Shaft-Hub-Connection

Technical data

KTR 603

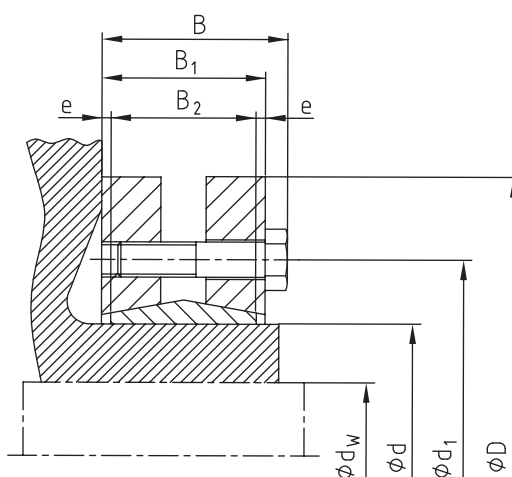

Type d x D [mm]	Shaft diameter dw [mm]	Transmittable torque or axial force		Dimensions [mm]					Clamping screws DIN 931 - 10.9 $\mu_{total} = 0,14$			Surface pressure clamping set / hollow shaft P _h [N/mm ²]	Weight -kg	Stock programme
		T [Nm]	F _{ax} [kN]	B	B ₁	B ₂	e	d ₁	M	z Number	T _a [Nm]			
14 x 38	11	30	6	15	11	7	2,00	23	5	4	4	186	0,20	
	12	50	8											
16 x 41	13	70	10	19	15	11	2,00	26	5	5	4	130	0,20	●
	14	90	12											
24 x 50	19	180	19	23	19	14	2,50	36	5	6	4	286	0,25	●
	20	210	21											
	21	250	23											
30 x 60	24	310	25	25	21	16	2,50	44	5	6	5,5	233	0,30	●
	25	340	27											
	26	380	29											
36 x 72	28	460	33	27	23	18	2,50	52	6	5	12	307	0,49	●
	30	590	39											
	31	630	40											
44 x 80	32	630	40	29	25	20	2,50	61	6	8	12	317	0,61	●
	35	780	44											
	36	860	48											
50 x 90	38	940	49	31	27	22	2,50	70	6	8	12	289	0,84	●
	40	1100	55											
	42	1300	62											
55 x 100	42	1200	57	34	30	23	3,50	75	6	8	12	252	1,20	●
	45	1500	66											
	48	1900	79											
62 x 110	48	1800	75	34	30	23	3,50	86	6	10	12	279	1,50	●
	50	2200	88											
	52	2400	92											
68 x 115	50	2000	80	34	30	23	3,50	86	6	10	12	255	1,60	●
	55	2500	91											
	60	3100	103											
75 x 138	55	2500	92	38	33	25	4,00	100	8	8	30	273	2,60	●
	60	3200	107											
	65	3900	121											
80 x 145	60	3200	107	38	33	25	3,50	100	8	8	30	256	2,80	●
	65	3900	120											
	70	4600	131											
85 x 155	65	4800	148	45	39	30	4,50	114	8	10	30	285	3,40	
	70	6100	175											
	75	7400	201											
90 x 155	65	4700	145	45	39	30	4,50	114	8	10	30	271	3,60	●
	70	6000	172											
	75	7200	194											
100 x 170	70	6900	199	49,5	44	34	5,00	124	8	12	30	258	4,60	●
	75	7500	199											
	80	9000	225											

● Clamping sets available from stock.
Other sizes on request.

CLAMPEX® - Shaft-Hub-Connection

Technical data

KTR 603



Type	Shaft diameter	Transmittable torque or axial force		Dimensions [mm]					Clamping screws DIN 931 - 10.9 $\mu_{\text{total}} = 0,14$			Surface pressure clamping set / hollow shaft	Weight -kg	Stock programme
				T [Nm]	F _{ax} [kN]	B	B ₁	B ₂	e	d ₁	M			
110 x 185	75	7200	194	57	50	39	5,50	136	10	10	59	244	6,20	●
	80	9000	227											
	85	11000	259											
115 x 188	80	8500	213	57	50	39	5,50	141	10	10	59	234	6,60	
	85	10000	237											
	90	12000	267											
120 x 215	80	10600	267	61	54	42	6,00	160	10	12	59	277	8,80	
	85	13300	312											
	90	14500	324											
125 x 215	85	11000	261	61	54	42	6,00	160	10	12	59	266	8,80	●
	90	13000	290											
	95	15000	318											
130 x 215	90	13700	306	59	52	42	5,00	160	10	12	59	285	8,20	
	95	15800	334											
	100	18200	365											
140 x 230	95	15000	350	68	60	46	7,00	175	12	10	100	264	10,00	●
	100	17000	342											
	105	20000	382											
155 x 263	105	20000	381	70	62	50	6,00	192	12	12	100	263	15,00	●
	110	23000	415											
	115	26000	453											
165 x 290	115	36000	626	78	68	56	6,00	210	16	8	250	277	22,00	●
	120	39000	648											
	125	44000	702											
175 x 300	125	40000	642	78	68	56	6,00	220	16	8	250	261	23,00	●
	130	44000	677											
	135	49000	726											
185 x 330	135	55000	816	96	86	71	7,50	236	16	10	250	244	36,00	
	140	60000	855											
	145	65000	902											
195 x 350	140	66000	943	96	86	71	7,50	246	16	12	250	277	40,00	
	150	76000	1013											
	155	82000	1057											
200 x 350	150	74000	982	96	86	71	7,50	246	16	12	250	270	41,00	
	155	80000	1035											
	160	86000	1081											
220 x 370	160	95000	1194	114	104	88	8,00	270	16	15	250	248	54,00	
	165	102000	1244											
	170	110000	1293											
240 x 405	170	120000	1408	122	109	92	8,50	295	20	12	490	272	67,00	
	180	140000	1558											
	190	160000	1690											
260 x 430	190	165000	1476	133	120	103	8,50	321	20	14	490	262	82,00	
	200	185000	1851											
	210	205000	1950											
280 x 460	210	217000	2067	147	134	114	10,00	346	20	16	490	251	102,00	
	220	244000	2222											
	230	270000	2352											
300 x 485	230	275000	2395	155	142	122	10,00	364	20	18	490	246	118,00	
	240	295000	2464											
	245	315000	2574											

● Clamping sets available from stock.

Other sizes on request.

CLAMPEX® - Shaft-Hub-Connection

Self-centering

KTR 105



- Compact design
- Short assembly times
- Suitable for small servo motors / pulleys
- QPQ surface protection on request
- Please find our detailed mounting instructions on our homepage (www.ktr.com)

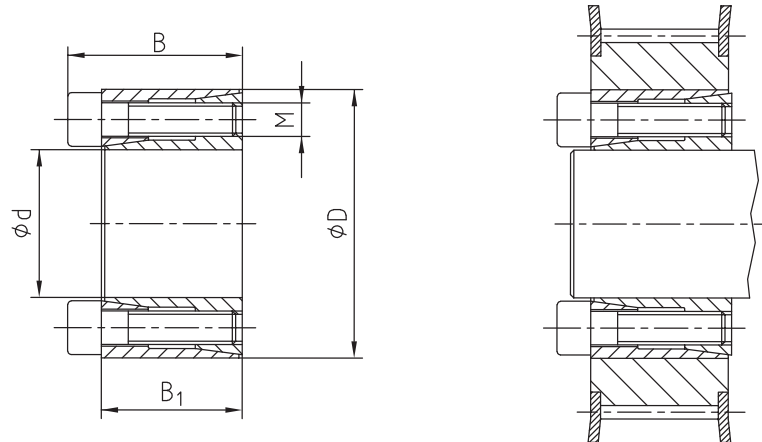

Assembly

Clean and lightly oil contact surfaces of shaft and hub. Insert the clamping element into hub fit and push it onto the shaft. Tighten the clamping screws crosswise, evenly and by degrees to the tightening torque T_a mentioned by means of the torque wrench. Check the tightening torque of all clamping screws in the order of arrangement. The figures T and F_{ax} mentioned in the table were calculated for an assembly with oil.

Note: Do not use any oil with molybdenum disulphide or high-pressure additions or grease reducing the coefficient of friction considerably. The clamping sets are delivered with oil. For assembly without oil, the figures mentioned in the table deviate.

Disassembly

Unscrew the clamping screws. Screw the screws into the pull-off thread, tighten them crosswise by degrees and evenly until the rear taper ring is released. For repeated application oil the screws and threads.

Tolerances, surfaces

One accurate turning process is sufficient:

$$R_z \leq 16\mu\text{m}$$

Maximum permissible tolerances:

h9 for the shaft - H9 for the hub

Axial displacement

During the assembly a slight axial movement of the hub towards the shaft may arise.

Centering

The clamping element KTR 105 is **self-centering**. Between shaft and hub the concentricity of the clamping elements is between **0,02 mm** and **0,04 mm**.

Orderform:

KTR 105	8	x	18
Type:	Size of inside diameter		Size of outside diameter

CLAMPEX® - Shaft-Hub-Connection

Technical data

KTR 105



Dimensions [mm]			Clamping screws DIN 912-12.9 $\mu_{total}=0,14$			Transmittable torque or axial force		Surface pressure between clamping set		Weight	Stock programme
d x D	B	B ₁	M	z Number	T _a ¹⁾	T	F _{ax}	Shaft P _w	Hub P _N	-kg	
[mm]	[mm]	[mm]			[Nm]	[Nm]	[kN]	[N/mm ²]	[N/mm ²]		
5 x 16	13,5	11	2,5	3	1,2	6	3	196	61	0,010	
6 x 16	13,5	11	2,5	3	1,2	8	3	163	61	0,012	●
6,35 x 16	13,5	11	2,5	3	1,2	8	3	154	61	0,012	
7 x 17	13,5	11	2,5	3	1,2	9	3	140	58	0,013	
8 x 18	13,5	11	2,5	3	1,2	10	3	123	54	0,015	●
9 x 20	15,5	13	2,5	4	1,2	16	3	121	54	0,020	●
9,5 x 20	15,5	13	2,5	4	1,2	16	3	115	54	0,020	
10 x 20	15,5	13	2,5	4	1,2	17	3	109	54	0,019	●
11 x 22	15,5	13	2,5	4	1,2	19	3	99	50	0,024	●
12 x 22	15,5	13	2,5	4	1,2	21	3	91	50	0,022	●
14 x 26	20	17	3	4	2,2	40	6	97	52	0,039	●
15 x 28	20	17	3	4	2,2	43	6	90	48	0,044	●
16 x 32	20	17	4	4	4,9	80	10	149	74	0,067	●
17 x 35	25	21	4	4	4,9	85	10	112	54	0,090	●
18 x 35	25	21	4	4	4,9	90	10	106	54	0,087	●
19 x 35	25	21	4	4	4,9	95	10	100	54	0,083	●
20 x 38	26	21	5	4	10	164	16	155	82	0,100	●
22 x 40	26	21	5	4	10	180	16	141	78	0,110	●
24 x 47	32	26	6	4	17	278	23	146	75	0,200	●
25 x 47	32	26	6	4	17	289	23	140	75	0,190	●
28 x 50	32	26	6	6	17	486	35	188	105	0,220	●
30 x 55	32	26	6	6	17	520	35	175	96	0,270	●
32 x 55	32	26	6	6	17	555	35	164	96	0,250	●
35 x 60	37	31	6	8	17	810	46	173	101	0,360	●
38 x 65	37	31	6	8	17	879	46	159	93	0,430	●
40 x 65	37	31	6	8	17	925	46	151	93	0,400	●
42 x 75	44	36	8	6	41	1346	64	170	95	0,670	
45 x 75	44	36	8	6	41	1442	64	159	95	0,630	
48 x 80	44	36	8	8	41	2052	85	198	119	0,740	●
50 x 80	44	36	8	8	41	2137	85	191	119	0,700	●

● Clamping sets available from stock

1) These are the maximum screw tightening torques. They can be reduced to max. 40% of the aforementioned figures with T, F_{ax} and P_w, P_N being reduced proportionally.

CLAMPEX® - Shaft-Hub-Connection

Self-centering

KTR 200 - KTR 201

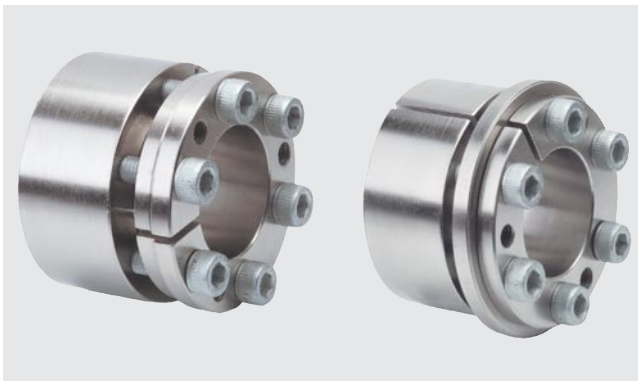

- Clamping element for universal use
- Wide range of applications
- Low-cost solution with average to high torques
- Please find our detailed mounting instructions on our homepage (www.ktr.com)

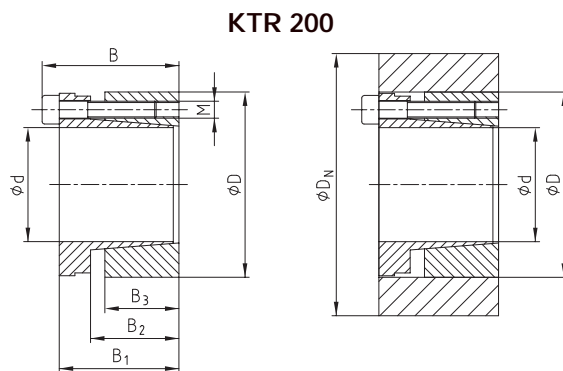

Considerably higher transmittable torque than KTR 201, slight axial movement of the hub

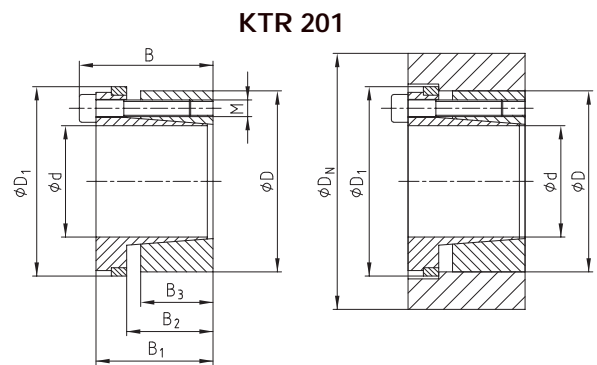

No axial movement of the hub, but lower transmittable torque than KTR 200

Assembly

Clean and lightly oil the contact surfaces of shaft and hub. Insert the clamping element into the hub fit and push it onto the shaft. Tighten the clamping screws crosswise, evenly and by degrees to the tightening torque T_a mentioned by means of the torque wrench. Check the tightening torque of all clamping screws in the order of arrangement. The figures T and F_{ax} mentioned in the table were calculated for an assembly with oil.

Note: Do not use any oil with molybdenum sulphide or high-pressure additions or grease reducing the coefficient of friction considerably. The clamping sets are delivered with oil. For assembly without oil the figures mentioned in the table deviate.

Disassembly

Unscrew the clamping screws. Screw the screws into the pull-off thread, tighten them crosswise by degrees and evenly until the rear taper ring is released. For repeated application oil the screws and threads.

Tolerances, surfaces

One accurate turning process is sufficient:
 $R_z \leq 16 \mu\text{m}$

Maximum permissible tolerances:
h8 for the shaft - H8 for the hub

Centering

The clamping elements KTR 200 and KTR 201 are **self-centering**. Between shaft and hub the concentricity of the clamping set is between **0,02** and **0,04** mm.

Orderform:

KTR 200	40	x	65
Type:	Size of inside diameter		Size of outside diameter

CLAMPEX® - Shaft-Hub-Connection

Technical data

KTR 200 - KTR 201



Dimensions [mm]						Clamping screws DIN 912, 12.9 $\mu_{total} = 0,14$				KTR 200				KTR 201				Weight -kg	KTR 200	KTR 201
										Transmittable torque or axial force		Surface pressure between clamping set		Transmittable torque or axial force		Surface pressure between clamping set				
										T [Nm]	F _{ax} [kN]	Shaft P _w [N/mm ²]	Hub P _N [N/mm ²]	T [Nm]	F _{ax} [kN]	Shaft P _w [N/mm ²]	Hub P _N [N/mm ²]			
d x D	B	B ₁	B ₂	B ₃	D ₁	M	z Number	KTR 200 T _a ¹⁾ [Nm]	KTR 201 T _a ¹⁾ [Nm]	T [Nm]	F _{ax} [kN]	Shaft P _w [N/mm ²]	Hub P _N [N/mm ²]	T [Nm]	F _{ax} [kN]	Shaft P _w [N/mm ²]	Hub P _N [N/mm ²]	-kg		
20 x 47	48	42	31	26	53	6	6	17	17	513	51	291	124	332	33	178	76	0,42	●	●
22 x 47	48	42	31	26	53	6	6	17	17	564	51	264	124	366	33	162	76	0,39	●	●
24 x 50	48	42	31	26	56	6	6	17	17	616	51	242	116	399	33	149	71	0,43	●	●
25 x 50	48	42	31	26	56	6	6	17	17	641	51	233	116	415	33	143	71	0,42	●	●
28 x 55	48	42	31	26	61	6	6	17	17	718	51	208	106	465	33	127	65	0,51	●	●
30 x 55	48	42	31	26	61	6	6	17	17	769	51	194	106	466	33	119	65	0,48	●	●
32 x 60	48	42	31	26	66	6	8	17	17	1094	68	242	129	709	44	149	79	0,57	●	●
35 x 60	48	42	31	26	66	6	8	17	17	1197	68	222	129	776	44	136	79	0,54	●	●
38 x 65	48	42	31	26	71	6	8	17	17	1299	68	204	119	842	44	125	73	0,63	●	●
40 x 65	48	42	31	26	71	6	8	17	17	1368	68	194	119	886	44	119	73	0,58	●	●
42 x 75	59	51	35	30	81	8	6	41	41	1990	95	222	124	1290	61	136	76	1,02	●	●
45 x 75	59	51	35	30	81	8	6	41	41	2132	95	207	124	1382	61	127	76	0,99	●	●
48 x 80	59	51	35	30	86	8	8	41	41	3033	126	259	155	1965	82	159	95	1,10	●	●
50 x 80	59	51	35	30	86	8	8	41	41	3159	126	248	155	2047	82	152	95	1,08	●	●
55 x 85	59	51	35	30	91	8	8	41	41	3475	126	226	146	2252	82	139	90	1,16	●	●
60 x 90	59	51	35	30	96	8	8	41	41	3791	126	207	138	2456	82	127	85	1,24	●	●
65 x 95	59	51	35	30	101	8	8	41	41	4107	126	191	131	2661	82	117	80	1,33	●	●
70 x 110	70	60	45	40	119	10	8	83	83	7023	201	211	134	4550	130	130	83	2,29	●	●
75 x 115	70	60	45	40	124	10	8	83	83	7524	201	197	129	4875	130	121	79	2,41	●	●
80 x 120	70	60	46	40	129	10	8	83	83	8026	201	185	123	5200	130	113	76	2,56	●	●
85 x 125	70	60	45	40	134	10	10	83	83	10659	251	217	148	6907	163	133	91	2,67	●	●
90 x 130	70	60	45	40	139	10	10	83	83	11286	251	205	142	7313	163	126	87	2,80	●	●
95 x 135	66	56	45	40	142	10	10	83	83	11373	239	186	131	7501	158	116	82	2,93	●	●
100 x 145	80	68	52	45	155	12	8	145	145	14607	292	191	132	9465	189	117	81	4,10	●	●
110 x 155	80	68	52	45	165	12	8	145	145	16068	292	174	123	10411	189	107	76	4,40	●	●
120 x 165	80	68	52	45	175	12	10	145	145	21910	365	199	145	14197	237	122	89	4,72	●	●
130 x 180	80	68	52	45	188	12	12	145	145	28483	438	221	159	18456	284	136	98	5,74	●	●
140 x 190	90	76	58	50	199	14	10	210	230	32023	457	193	142	22726	325	130	95	6,92		
150 x 200	90	76	58	50	209	14	12	210	230	41173	549	216	162	29219	390	145	109	7,24	●	
160 x 210	90	76	58	50	219	14	12	210	230	43918	549	202	154	31167	390	136	104	7,76		
170 x 225	90	76	58	50	234	14	14	210	230	54440	640	222	168	38634	455	149	113	8,98		
180 x 235	90	76	58	50	244	14	14	210	230	57642	640	210	161	40907	455	141	108	9,50		

● Clamping sets available from stock.

1) These are the maximum screw tightening torques. They can be reduced to max. 40% of the aforementioned figures with T, F_{ax} and P_w, P_N being reduced proportionally.

CLAMPEX® - Shaft-Hub-Connection

Self-centering

KTR 203 - KTR 206



- Clamping set for universal applications
- Short dimensions
- Operation as with KTR 200/201
- Please find our detailed mounting instructions on our homepage (www.ktr.com)

KTR 203

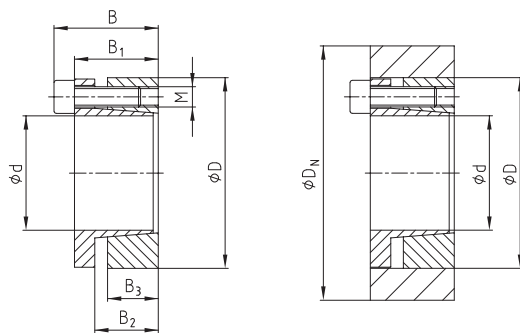

Higher transmittable torque than KTR 206, slight axial movement of the hub

KTR 206

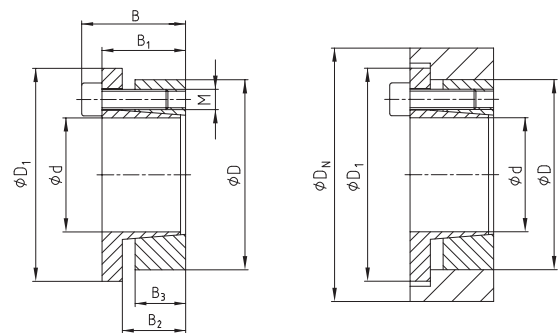

No axial movement of the hub, but lower transmittable torque than KTR 203

Assembly

Clean and lightly oil the contact surfaces of shaft and hub. Insert the clamping element into the hub fit and push it onto the shaft. Tighten the clamping screws crosswise, evenly and by degrees to the tightening torque T_a mentioned by means of the torque wrench. Check the tightening torque of all clamping screws in the order of arrangement. The figures T and F_{ax} mentioned in the table were calculated for an assembly with oil.

Note: Do not use any oil with molybdenum sulphide or high-pressure additions or grease reducing the coefficient of friction considerably. The clamping sets are delivered with oil. For assembly without oil the figures mentioned in the table deviate.

Disassembly

Unscrew the clamping screws. Screw the screws into the pull-off thread, tighten them crosswise by degrees and evenly until the rear taper ring is released. For repeated application oil the screws and threads.

Tolerances, surfaces

One accurate turning process is sufficient:
 $R_z \leq 16 \mu\text{m}$

Maximum permissible tolerances:
h8 for the shaft - H8 for the hub

Centering

The clamping elements KTR 203 and KTR 206 are **self-centering**. Between shaft and hub the concentricity of the clamping set is between **0,02** and **0,04** mm.

Orderform:

KTR 203	40	x	65
Type:	Size of inside diameter		Size of outside diameter

CLAMPEX® - Shaft-Hub-Connection

Technical data

KTR 203 - KTR 206



Dimensions [mm]							Clamping screws DIN 912, 12.9 $\mu_{total} = 0,14$		KTR 203					KTR 206					KTR 203	KTR 206		
									Transmittable torque or axial force			Surface pressure between clamping set		Weight - kg	Transmittable torque or axial force			Surface pressure between clamping set			Weight -kg	
									T_a 1) [Nm]	T [Nm]	F_{ax} [kN]	Shaft P_w [N/mm ²]	Hub P_N [N/mm ²]		T_a 1) [Nm]	T [Nm]	F_{ax} [kN]	Shaft P_w [N/mm ²]				Hub P_N [N/mm ²]
d x D	B	B ₁	B ₂	B ₃	D ₁	M	z No.															
20 x 47	34	28	22	17	56	6	6	14	428	43	334	142	0,25	17	332	33	259	110	0,26	●	●	
22 x 47	34	28	22	17	56	6	6	14	471	43	304	142	0,23	17	366	33	236	110	0,24	●	●	
24 x 50	34	28	22	17	59	6	6	14	514	43	278	134	0,26	17	399	33	216	104	0,27	●	●	
25 x 50	34	28	22	17	59	6	6	14	535	43	267	134	0,25	17	415	33	207	104	0,26	●	●	
28 x 55	34	28	22	17	64	6	6	14	599	43	239	121	0,31	17	465	33	185	94	0,32	●	●	
30 x 55	34	28	22	17	64	6	6	14	642	43	223	121	0,29	17	499	33	173	94	0,30	●	●	
32 x 60	34	28	22	17	69	6	8	14	913	57	278	148	0,34	17	709	44	216	115	0,35	●	●	
35 x 60	34	28	22	17	69	6	8	14	999	57	254	148	0,33	17	776	44	198	115	0,34	●	●	
38 x 65	34	28	22	17	74	6	8	14	1084	57	234	137	0,38	17	842	44	182	106	0,39	●	●	
40 x 65	34	28	22	17	74	6	8	14	1141	57	223	137	0,34	17	886	44	173	106	0,35	●	●	
42 x 75	41	33	25	20	84	8	8	35	2207	105	332	186	0,59	41	1719	82	259	145	0,60	●	●	
45 x 75	41	33	25	20	84	8	8	35	2364	105	310	186	0,58	41	1842	82	241	145	0,59	●	●	
48 x 80	41	33	25	20	89	8	8	35	2522	105	290	174	0,64	41	1965	82	226	136	0,65	●	●	
50 x 80	41	33	25	20	89	8	8	35	2627	105	279	174	0,63	41	2047	82	217	136	0,64	●	●	
55 x 85	41	33	25	20	94	8	8	35	2890	105	253	164	0,69	41	2252	82	197	128	0,70	●	●	
60 x 90	41	33	25	20	99	8	8	35	3152	105	232	155	0,73	41	2456	82	181	121	0,74	●	●	
65 x 95	41	33	25	20	104	8	8	35	3415	105	214	147	0,79	41	2661	82	167	114	0,80	●	●	
70 x 110	50	40	30	24	119	10	8	70	5934	170	268	170	1,47	83	4550	130	205	131	1,58	●	●	
75 x 115	50	40	30	24	124	10	8	70	6358	170	250	163	1,55	83	4875	130	192	125	1,66	●	●	
80 x 120	50	40	30	24	129	10	8	70	6782	170	234	156	1,65	83	5200	130	180	120	1,77	●	●	
85 x 125	50	40	30	24	134	10	10	70	9007	212	276	187	1,72	83	6907	163	211	144	1,84	●	●	
90 x 130	50	40	30	24	139	10	10	70	9537	212	260	180	1,81	83	7313	163	200	138	1,94	●	●	
95 x 135	50	40	30	24	144	10	10	70	9611	202	235	166	1,90	83	7501	158	184	129	2,03	●	●	
100 x 145	56	44	31	26	154	12	8	115	11719	234	239	165	2,48	145	9465	189	193	133	2,68	●	●	
110 x 155	56	44	31	26	164	12	8	115	12891	234	217	154	2,66	145	10411	189	176	125	2,86	●	●	
120 x 165	56	44	31	26	174	12	9	115	15821	264	224	163	2,84	145	12777	213	181	132	3,06	●	●	
130 x 180	64	54	39	34	189	12	12	115	22853	352	211	152	4,45	145	18456	284	170	123	4,69	●	●	
140 x 190	68	54	39	34	199	14	9	185	25699	367	205	151	4,62	230	20453	292	163	120	4,94			
150 x 200	68	54	39	34	209	14	10	185	30595	408	212	159	4,80	230	24349	325	169	127	5,14			
160 x 210	68	54	39	34	219	14	12	185	39161	490	239	182	5,18	230	31167	390	190	145	5,54			
170 x 225	78	64	49	44	234	14	12	185	41609	490	225	170	7,33	230	33115	390	179	135	7,71			
180 x 235	78	64	49	44	244	14	12	185	44056	490	212	163	7,77	230	35063	390	169	129	8,17			

● Clamping sets available from stock.

1) These are the maximum screw tightening torques. They can be reduced to max. 40% of the aforementioned figures with T , F_{ax} and P_w , P_N being reduced proportionally.

CLAMPEX® - Shaft-Hub-Connection

Self-centering

KTR 250



- Clamping set specifically suitable for hubs with a small wall thickness
- Reduction of costs by saving material
- Short assembly times
- Small radial mounting dimensions
- Please find our detailed mounting instructions on our homepage (www.ktr.com)

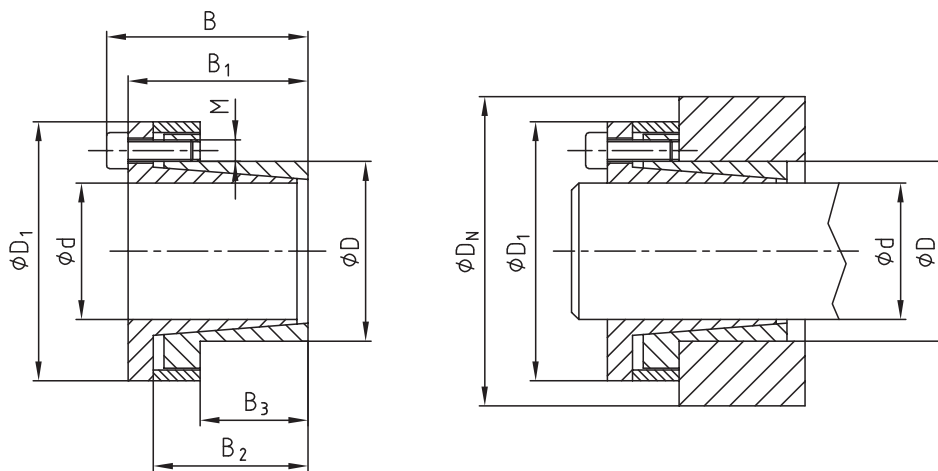

Assembly

Clean and lightly oil the contact surfaces of shaft and hub. Insert the clamping element into the hub fit and push it onto the shaft. Tighten the clamping screws crosswise, evenly and by degrees to the tightening torque T_a mentioned by means of the torque wrench. Check the tightening torque of all clamping screws in the order of arrangement. The figures T and F_{ax} mentioned in the table were calculated for an assembly with oil.

Note: Do not use any oil with molybdenum sulphide or high-pressure additions or grease reducing the coefficient of friction considerably. The clamping sets are delivered with oil. For assembly without oil the figures mentioned in the table deviate.

Disassembly

Unscrew the clamping screws. Screw the screws into the pull-off thread, tighten them crosswise by degrees and evenly until the rear taper ring is released. For repeated application oil the screws and threads.

Tolerances, surfaces

One accurate turning process is sufficient:
 $R_z \leq 16 \mu\text{m}$

Maximum permissible tolerances:
h8 for the shaft - H8 for the hub

Centering

The clamping element KTR 250 is **self-centering**. Between shaft and hub the concentricity of the clamping set is between 0,02 and 0,04 mm.

Orderform:

KTR 250	50	x	65
Type:	Size of inside diameter		Size of outside diameter

CLAMPEX® - Shaft-Hub-Connection

Technical data

KTR 250



d x D	Dimensions [mm]					Clamping screws DIN 912-12.9 $\mu_{\text{total}} = 0,14$			Transmittable torque or axial force		Surface pressure between clamping set		Weight -kg	Stock programme
	B	B ₁	B ₂	B ₃	D ₁	M	z Number	T _a ¹⁾ [Nm]	T [Nm]	F _{ax} [kN]	Shaft P _w [N/mm ²]	Hub P _N		
6 x 14	24,5	21,5	18,5	9	25	3	4	2	14	5	252	108	0,1	●
8 x 15	29	25	22	12	27	4	3	5	27	7	210	112	0,12	●
9 x 16	30	26	23	14	28	4	4	5	40	9	207	116	0,15	●
10 x 16	30	26	22,5	14	29	4	4	5	46	9	192	120	0,15	●
11 x 18	30	26	23	14	32	4	4	5	49	9	169	103	0,18	●
12 x 18	30	26	22,5	14	32	4	4	5	55	9	160	106	0,18	●
14 x 23	30	26	22,5	14	38	4	4	5	64	9	137	83	0,2	●
15 x 24	42	36	28,5	16	44	6	4	15	139	19	227	142	0,31	●
16 x 24	42	36	28,5	16	44	6	4	15	148	19	213	142	0,3	●
18 x 26	44	38	31	18	47	6	4	17	199	22	191	132	0,32	●
19 x 27	44	38	31	18	48	6	4	17	210	22	181	127	0,35	●
20 x 28	44	38	31	18	49	6	4	17	222	22	172	123	0,36	●
22 x 32	51	45	38	25	54	6	4	17	244	22	112	77	0,45	●
24 x 34	51	45	38	25	56	6	4	17	266	22	103	73	0,48	●
25 x 34	51	45	38	25	56	6	4	17	277	22	99	73	0,5	●
28 x 39	51	45	38	25	61	6	6	17	465	33	133	95	0,52	●
30 x 41	51	45	38	25	62	6	6	17	499	33	124	91	0,53	●
32 x 43	56	50	43	30	65	6	8	17	689	43	150	112	0,58	●
35 x 47	56	50	43	30	69	6	8	17	776	44	118	88	0,69	●
38 x 50	56	50	43	30	72	6	8	17	842	44	109	82	0,73	●
40 x 53	56	50	43	30	75	6	8	17	886	44	103	78	0,8	●
42 x 55	73	65	57	40	78	6	8	17	904	43	89	68	0,83	●
45 x 59	73	65	57	40	85	8	8	41	1842	82	127	97	1,4	●
48 x 62	78	70	62	45	87	8	8	41	1909	80	103	80	1,42	●
50 x 65	78	70	62	45	92	8	10	41	2559	102	127	98	1,6	●
55 x 71	83	75	67	50	98	8	10	41	2815	102	104	81	1,9	●
60 x 77	83	75	67	50	104	8	10	41	3070	102	95	74	2,05	●
65 x 84	83	75	67	50	111	8	10	41	3326	102	88	68	2,15	●
70 x 90	101	91	80	60	119	10	10	83	5688	163	108	84	3,35	●
75 x 95	101	91	80	60	126	10	10	83	6094	163	101	80	3,6	●
80 x 100	106	96	85	65	131	10	12	83	7801	195	105	84	3,75	●
85 x 106	106	96	85	65	137	10	12	83	8288	195	99	79	4,05	●
90 x 112	106	96	85	65	143	10	15	83	10970	244	116	93	4,32	●
95 x 120	106	96	85	65	153	10	15	83	11579	244	110	87	4,5	●
100 x 125	114	102	85	65	162	12	12	145	14197	284	122	98	4,8	●
110 x 140	140	128	114	90	180	12	12	145	15174	276	78	61	6,15	●
120 x 155	140	128	115	90	198	12	12	145	16554	276	71	55	10,14	●
130 x 165	140	128	115	90	208	12	16	145	23911	368	88	69	11,89	●

● Clamping sets available from stock.

1) These are the maximum screw tightening torques. They can be reduced to max. 40% of the aforementioned figures with T, F_{ax} and P_w, P_N being reduced proportionally.

CLAMPEX® - Shaft-Hub-Connection

Self-centering

For disk and flange shape drive components

KTR 225



- For the same diameter of the external ring various bore diameters are available
- Only one bore for each size necessary for the hub
- Reduction of components and costs
- Short assembly times
- Please find our detailed mounting instructions on our homepage (www.ktr.com)

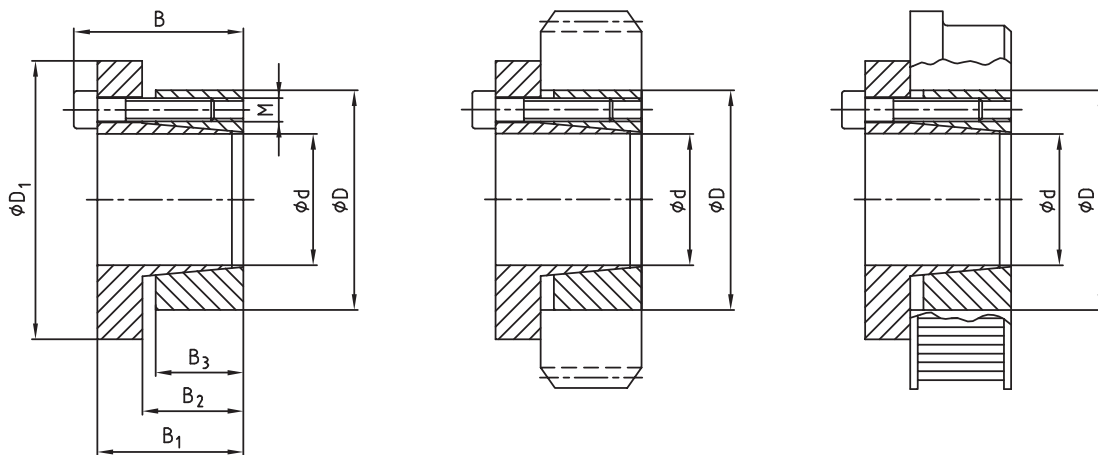

Assembly

Clean and lightly oil the contact surfaces of shaft and hub. Insert the clamping element into the hub fit and push it onto the shaft. Tighten the clamping screws crosswise, evenly and by degrees to the tightening torque T_a mentioned by means of the torque wrench. Check the tightening torque of all clamping screws in the order of arrangement. The figures T and F_{ax} mentioned in the table were calculated for an assembly with oil.

Note: Do not use any oil with molybdenum sulphide or high-pressure additions or grease reducing the coefficient of friction considerably. The clamping sets are delivered with oil. For assembly without oil the figures mentioned in the table deviate.

Disassembly

Unscrew the clamping screws. Screw the screws into the pull-off thread, tighten them crosswise by degrees and evenly until the rear taper ring is released. For repeated application oil the screws and threads.

Tolerances, surfaces

One accurate turning process is sufficient:
 $R_z \leq 16 \mu\text{m}$

Maximum permissible tolerances:
h8 for the shaft - H8 for the hub

Centering

The clamping element KTR 225 is **self-centering**. Between shaft and hub the concentricity of the clamping set is between 0,02 and 0,04 mm.

Axial movement

During the tightening of the screws there is no axial movement of the hub towards the shaft.

Orderform:

KTR 225	28	x	65
Type:	Size of inside diameter		Size of outside diameter

CLAMPEX® - Shaft-Hub-Connection

Technical data

KTR 225



d x D	Dimensions [mm]					Clamping screws DIN 912,12.9 $\mu_{total} = 0,14$			Transmittable torque or axial force		Surface pressure between clamping sets		Weight -kg	Stock programme
	B	B ₁	B ₂	B ₃	D ₁	M	Z Number	T _a ¹⁾ [Nm]	T [Nm]	F _{ax} [kN]	Shaft P _w [N/mm ²]	Hub P _N		
14 x 55						8	4	41	139	20	263	122	0,5	●
16 x 55						8	4	41	195	24	244	122	0,49	●
18 x 55						8	4	41	250	28	228	122	0,48	●
19 x 55						8	4	41	278	29	221	122	0,47	●
20 x 55	39	31	23	17	62	8	4	41	306	31	214	122	0,46	●
22 x 55						8	4	41	362	33	203	122	0,45	●
24 x 55						8	4	41	418	35	193	122	0,43	●
25 x 55						8	4	41	446	36	188	122	0,42	●
28 x 55						8	4	41	529	38	177	122	0,39	●
30 x 55						8	4	41	585	39	170	122	0,37	●
24 x 65						8	5	41	467	39	211	129	0,66	●
25 x 65						8	5	41	500	40	206	129	0,65	●
28 x 65						8	5	41	599	43	193	129	0,62	●
30 x 65	39	31	23	17	72	8	5	41	665	44	186	129	0,6	●
32 x 65						8	5	41	731	46	179	129	0,58	●
35 x 65						8	5	41	830	47	171	129	0,54	●
38 x 65						8	5	41	929	49	164	129	0,5	●
40 x 65						8	5	41	995	50	161	129	0,47	●
30 x 80						8	7	41	898	60	210	125	1,08	
32 x 80						8	7	41	985	62	202	125	1,05	
35 x 80						8	7	41	1114	64	191	125	1,01	
38 x 80						8	7	41	1244	65	182	125	0,97	
40 x 80	42	34	26	20	88	8	7	41	1331	67	177	125	0,94	●
42 x 80						8	7	41	1417	67	172	125	0,91	
45 x 80						8	7	41	1547	69	166	125	0,85	
48 x 80						8	7	41	1677	70	161	125	0,79	
50 x 80						8	7	41	1764	71	159	125	0,75	●

Assembly with belt drive

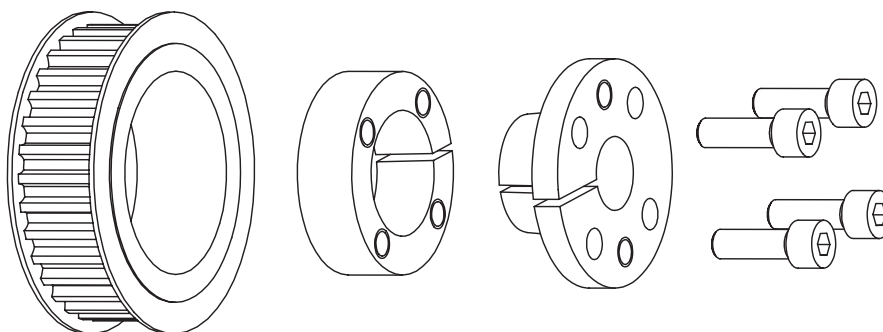

For different shaft diameters only one cylindrical bore dimension is necessary in the pulley in case of KTR 225.

● Clamping sets available from stock.

1) These are the maximum screw tightening torques. They can be reduced to max. 40% of the aforementioned figures with T, F_{ax} and P_w, P_N being reduced proportionally.

CLAMPEX® - Shaft-Hub-Connection

Self-centering

KTR 400



- Clamping set suitable for high loads
- Specifically suitable for vibratory torques
- Typical applications: flywheels, belt drums
- Torque factor

1 off	1 x T
2 off	1,9 x T
3 off	2,7 x T
4 off	3,6 x T
- Please find our detailed mounting instructions on our homepage (www.ktr.com)

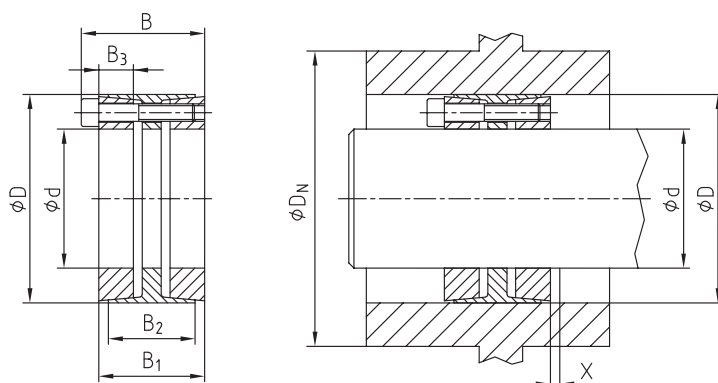

Formula to calculate space x left for disassembly:

$$x = \frac{(B1 - B2)}{2}$$

Assembly

Clean and lightly oil the contact surfaces of shaft and hub. Insert the clamping element into the hub fit and push it onto the shaft. Tighten the clamping screws evenly and crosswise. Here please increase the tightening torque step by step. This must be repeated until reaching the indicated tightening torque with all clamping screws.

Note: Do not use any oil with molybdenum sulphide or high-pressure additions or grease reducing the coefficient of friction considerably. The clamping sets are delivered with oil. For assembly without oil the figures mentioned in the table deviate.

Disassembly

Unscrew all clamping screws and screw them into the pull-off threads of the front taper ring. Tighten the screws crosswise by degrees and evenly to half the tightening torque T_a . Afterwards repeat this process to the full tightening torque. As soon as the front taper ring is released, screw the clamping screws into the pull-off threads of the spacer ring in order to release the rear taper ring.

Note: If the clamping element KTR 400 is reused, please make sure that the pull-off thread of the front taper ring and the spacer ring are situated in the original position. Here the slots of the front and of the back pressure ring and those of the external ring must be flush.

Tolerances, surfaces

One accurate turning process is sufficient:
 $R_z \leq 16 \mu\text{m}$.
 Maximum permissible tolerances:
h8 for the shaft - H8 for the hub.

Centering

The clamping element KTR 400 is **self-centering**. Between shaft and hub the concentricity of the clamping set is between **0,02 and 0,04 mm**.

Axial movement

During the assembly a slight axial movement of the hub towards the shaft may arise.

Example of assembly

Drive of conveyor belt drum

The following conditions should be adhered to as limiting values for CLAMPEX clamping sets with load by bending: Direction angles α on the contact position shaft-clamping set $\leq 6^\circ$ or maximum shaft bending f_m in the bearing area:

$$f_m \leq l \cdot (\sqrt[3]{2000} - \sqrt[3]{3000})$$

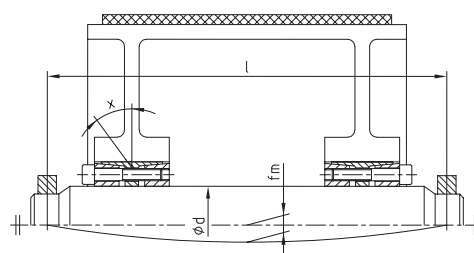

Orderform:

KTR 400	100	x	145
Type	Size of inside diameter		Size of outside diameter

CLAMPEX® - Shaft-Hub-Connection

Technical data

KTR 400



Dimensions [mm]					Standard industrial applications							Applications with components subject to bending and torsion									
					Clamping screws DIN 912, 12.9 $\mu_{total} = 0,14$			Transmittable torque or axial force		Surface pressure between clamping set		Clamping screws DIN 912, 12.9 $\mu_{total} = 0,14$			Transmittable torque or axial force with $Mb_{perm.}$		Transmittable bending moment		Surface pressure between clamping set		Weight -kg
d x D	B	B ₁	B ₂	B ₃	M	z No.	T _a ¹⁾ [Nm]	T [Nm]	F _{ax} [kN]	Shaft P _w [N/mm ²]	Hub P _N	M	z No.	T _a [Nm]	T [Nm]	F _{ax} [kN]	Mb _{perm.} [Nm]	Shaft P _w [N/mm ²]	Hub P _Z		
24x55	46	40	32	12	6	6	17	756	63	322	105	6	6	14	537	45	246	309	101	0,54	
25x55	46	40	32	12	6	6	17	787	63	309	105	6	6	14	555	44	256	298	102	0,53	
28x55	46	40	32	12	6	6	17	882	63	276	105	6	6	14	608	43	287	270	103	0,50	
30x55	46	40	32	12	6	6	17	945	63	258	105	6	6	14	642	43	307	255	104	0,47	●
32x60	60	54	44	17	6	7	17	1176	73	199	82	6	7	14	745	47	638	206	85	0,77	
35x60	60	54	44	17	6	7	17	1286	73	182	82	6	7	14	790	45	698	192	86	0,71	●
38x75	62	54	44	17	8	7	41	2579	136	310	121	8	7	35	1812	95	758	298	116	1,25	
40x75	62	54	44	17	8	7	41	2715	136	294	121	8	7	35	1888	94	798	285	117	1,21	●
42x75	62	54	44	17	8	7	41	2851	136	280	121	8	7	35	1963	93	838	273	118	1,16	
45x75	62	54	44	17	8	7	41	3054	136	261	121	8	7	35	2073	92	898	257	119	1,08	●
48x80	72	64	56	22	8	8	41	3723	155	216	102	8	8	35	2408	100	1577	220	104	1,45	●
50x80	72	64	56	23	8	8	41	3664	147	188	93	8	8	35	2267	91	1779	196	97	1,38	●
55x85	72	64	58	23	8	8	41	4031	147	171	88	8	8	35	2408	88	1957	182	93	1,49	●
60x90	72	64	58	23	8	10	41	5497	183	196	103	8	10	35	3447	115	2134	203	107	1,60	●
65x95	72	64	58	23	8	10	41	5955	183	181	98	8	10	35	3633	112	2312	190	103	1,70	●
70x110	88	78	70	28	10	10	83	10182	291	219	111	10	10	69	6619	189	3659	222	113	3,12	●
75x115	88	78	70	28	10	10	83	10910	291	204	107	10	10	69	6950	185	3920	210	110	3,29	●
80x120	88	78	70	28	10	12	83	13964	349	230	122	10	12	69	9200	230	4181	231	123	3,46	●
85x125	88	78	70	28	10	12	83	14837	349	216	118	10	12	69	9613	226	4443	220	120	3,64	●
90x130	88	78	70	28	10	12	83	15710	349	204	113	10	12	69	10008	222	4704	210	116	3,81	●
95x135	88	78	70	28	10	12	83	16583	349	193	109	10	12	69	10383	219	4965	201	113	3,98	●
100x145	112	100	92	35	12	12	145	25415	508	214	112	12	12	120	16527	331	8687	219	115	6,12	●
110x155	112	100	92	35	12	12	145	27956	508	195	105	12	12	120	17658	321	9445	203	110	6,62	●
120x165	112	100	92	35	12	14	145	35581	593	208	115	12	14	120	22948	382	10304	214	119	7,12	●
130x180	130	116	108	41	14	12	230	45333	697	193	106	14	12	190	28502	438	15350	201	110	9,98	●
140x190	130	116	108	41	14	14	230	56957	814	209	117	14	14	190	36719	525	16531	215	120	10,62	●
150x200	130	116	108	41	14	16	230	69743	930	223	127	14	16	190	45796	611	17712	226	129	11,26	●
160x210	130	116	108	41	14	16	230	74392	930	209	121	14	16	190	47958	599	18893	215	124	11,91	●
170x225	162	146	136	52	16	14	355	96123	1131	189	109	16	14	295	59316	698	32060	196	113	17,60	●
180x235	162	146	136	52	16	16	355	116317	1292	203	119	16	16	295	73592	818	33946	209	122	18,49	●
190x250	162	146	136	52	16	16	355	122779	1292	193	112	16	16	295	76340	804	35831	200	116	21,39	●
200x260	162	146	136	52	16	16	355	129241	1292	183	108	16	16	295	78946	789	37717	192	113	22,36	●
220x285	162	146	136	52	16	20	355	177706	1616	208	123	16	2	295	113209	1029	41489	213	125	26,59	●
240x305	162	146	136	52	16	22	355	213248	1777	210	126	16	22	295	136190	1135	45261	214	129	28,70	●
260x325	164	148	134	55	16	21	355	233398	1795	185	122	16	21	295	143090	1101	51099	193	127	31,23	
280x355	197	177	165	66	20	18	690	336303	2402	192	121	20	18	580	210027	1500	81312	200	126	46,77	
300x375	197	177	165	66	20	20	690	400360	2669	199	127	20	20	580	253018	1687	87120	206	132	49,72	
320x405	197	177	165	66	20	21	690	448404	2803	196	124	20	21	580	218947	1762	92928	203	128	60,52	
340x425	197	177	165	66	20	22	690	499116	2936	193	123	20	22	580	312383	1838	98736	201	128	63,86	
360x455	224	202	190	76	22	21	930	627940	3489	188	119	22	21	780	389170	2162	138624	196	124	86,78	
380x475	224	202	190	76	22	22	930	694389	3655	186	119	22	22	780	429232	2259	146325	195	125	91,04	
400x495	224	202	190	76	22	24	930	797384	3987	193	125	22	24	780	498899	2494	154027	201	130	95,30	

● Clamping sets available from stock.

1) These are the maximum screw tightening torques. They can be reduced to max. 40% of the aforementioned figures with T, Fax and Pw, PN being reduced proportionally.

Other sizes on request .

CLAMPEX® - Shaft-Hub-Connection

Not self-centering

KTR 100



- „Typical clamping set“
- Axial fastening of the hub
- Torque factor

1 off	1 x T
2 off	1,9 x T
3 off	2,7 x T
4 off	3,6 x T
- Please find our detailed mounting instructions on our homepage (www.ktr.com)

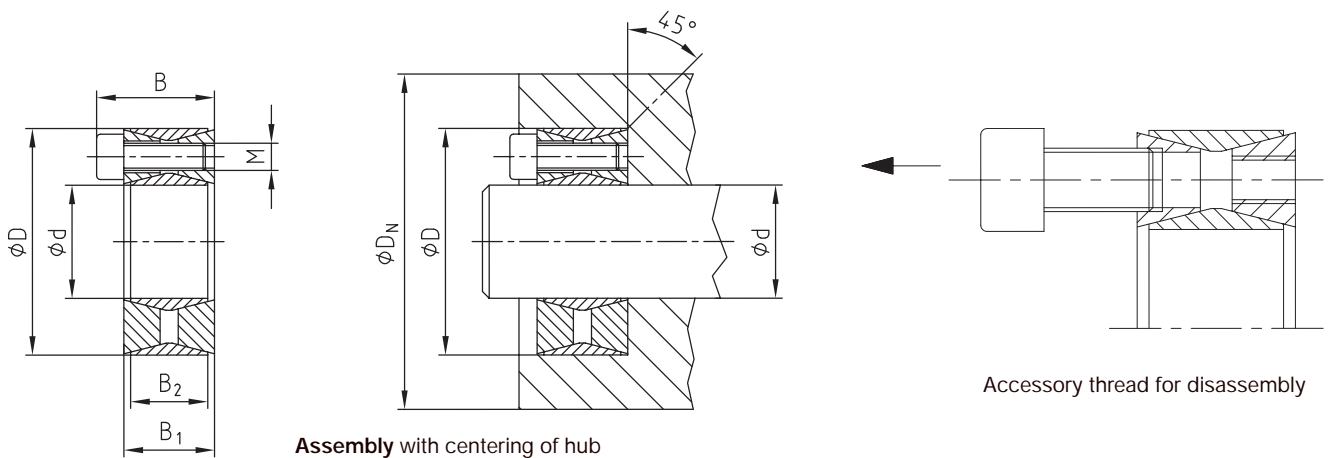

Assembly

Clean and lightly oil the contact surfaces of shaft and hub. Insert the clamping element into the hub fit and push it onto the shaft. Tighten the chromated screws until the internal ring is in contact with the shaft and the external ring is in contact with the hub. Afterwards tighten the clamping screws crosswise by degrees and evenly until the tightening torque T_a mentioned in the table is achieved. The figures T and F_{ax} mentioned in the table were calculated for an assembly with oil.

Note: Do not use any oil with molybdenum sulphide or high-pressure additions or grease reducing the coefficient of friction considerably. The clamping sets are delivered with oil. For assembly without oil the figures mentioned in the table deviate.

Demontage

Unscrew all clamping screws. In normal cases the clamping element releases automatically. Otherwise lightly strike with a hammer onto the detached screws in order to push back the rear taper ring. By using the accessory threads the detached clamping set can be pulled-off.

Note: The accessory threads for the disassembly have approx. 3-5 supporting turns and are not cut. These are no threads for forcing screws.

Tolerances, surfaces

One accurate turning process is sufficient:
 $R_z \leq 16 \mu\text{m}$

Maximum permissible tolerances:
h11 for the shaft - H11 for the hub

Centering

The clamping element KTR 100 is **not self-centering**. The concentricity of the hub towards the shaft merely depends on the fit and length of the pilot.

Axial movement

During the tightening of the screws there is no axial movement of the hub towards the shaft.

Orderform:

KTR 100	50	x	80
Type:	Size of inside diameter		Size of outside diameter

CLAMPEX® - Shaft-Hub-Connection

Technical data

KTR 100



Dimensions [mm]				Clamping screws DIN 912, 12.9 $\mu_{\text{total}} = 0,14$			Transmittable torque or axial force		Surface pressure between clamping sets		Weight	Stock programme
d x D	B	B ₁	B ₂	M	z Number	T _a ¹⁾ [Nm]	T [Nm]	F _{ax} [kN]	Shaft P _w [N/mm ²]	Hub P _N	-kg	
18 x 47	26	20	17	M 6	8	15	240	27	289	111	0,24	●
19 x 47	26	20	17	M 6	8	15	254	27	274	111	0,24	●
20 x 47	26	20	17	M 6	8	15	267	27	260	111	0,23	●
22 x 47	26	20	17	M 6	8	15	294	27	237	111	0,23	●
24 x 50	26	20	17	M 6	8	15	320	27	217	104	0,26	●
25 x 50	26	20	17	M 6	8	15	334	27	208	104	0,25	●
28 x 55	26	20	17	M 6	12	15	560	40	279	142	0,30	●
30 x 55	26	20	17	M 6	12	15	600	40	260	142	0,29	●
32 x 60	26	20	17	M 6	12	15	641	40	244	130	0,34	●
35 x 60	26	20	17	M 6	12	15	701	40	223	130	0,32	●
38 x 65	26	20	17	M 6	15	15	951	50	257	150	0,36	●
40 x 65	26	20	17	M 6	15	15	1001	50	244	150	0,34	●
42 x 75	32	24	20	M 8	12	37	1506	72	283	159	0,60	●
45 x 75	32	24	20	M 8	12	37	1614	72	264	159	0,57	●
48 x 80	32	24	20	M 8	12	37	1721	72	248	149	0,60	●
50 x 80	32	24	20	M 8	12	37	1793	72	238	149	0,60	●
55 x 85	32	24	20	M 8	15	37	2465	90	270	175	0,63	●
60 x 90	32	24	20	M 8	15	37	2690	90	248	165	0,69	●
65 x 95	32	24	20	M 8	15	37	2914	90	229	156	0,73	●
70 x 110	38	28	24	M 10	15	70	4992	143	282	179	1,26	●
75 x 115	38	28	24	M 10	15	70	5349	143	263	171	1,33	●
80 x 120	38	28	24	M 10	15	70	5705	143	246	164	1,40	●
85 x 125	38	28	24	M 10	15	70	6092	143	232	158	1,49	●
90 x 130	38	28	24	M 10	15	70	6418	143	219	152	1,53	●
95 x 135	38	28	24	M 10	18	70	8130	171	249	175	1,62	●
100 x 145	42	30	26	M 12	15	127	10881	218	278	191	2,01	●
110 x 155	42	30	26	M 12	15	127	11969	218	252	179	2,15	●
120 x 165	42	30	26	M 12	16	127	13927	232	247	179	2,35	●
130 x 180	50	38	34	M 12	20	127	18860	290	218	157	3,51	●
140 x 190	50	38	34	M 12	22	127	22341	319	222	164	3,85	●
150 x 200	50	38	34	M 12	24	127	26113	348	226	170	4,07	●
160 x 210	50	38	34	M 12	26	127	30175	377	230	175	4,30	●
170 x 225	58	44	38	M 14	22	195	35710	420	216	163	5,78	●
180 x 235	58	44	38	M 14	24	195	41248	458	222	170	6,05	●
190 x 250	66	52	46	M 14	28	195	50796	535	203	154	8,25	●
200 x 260	66	52	46	M 14	30	195	57289	573	206	159	8,65	●
220 x 285	72	56	50	M 16	26	300	74838	680	205	158	11,22	●
240 x 305	72	56	50	M 16	30	300	94202	785	217	171	12,20	●
260 x 325	72	56	50	M 16	34	300	115659	890	227	182	13,20	
280 x 355	87	66	60	M 18	32	410	139261	995	196	155	19,20	
300 x 375	87	66	60	M 18	36	410	167860	1119	206	165	20,50	
320 x 405	101	78	72	M 20	36	590	240190	1501	216	171	29,60	
340 x 425	101	78	72	M 20	36	590	255201	1501	203	163	31,10	
360 x 455	116	90	84	M 22	36	790	328186	1823	200	158	42,20	
380 x 475	116	90	84	M 22	36	790	346419	1823	189	152	44,00	
400 x 495	116	90	84	M 22	36	790	364651	1823	180	145	46,00	
420 x 515	116	90	84	M 22	40	790	371953	1771	196	160	50,00	
440 x 545	130	102	96	M 24	40	1000	453797	2063	188	152	64,60	
460 x 565	130	102	96	M 24	40	1000	467548	2033	180	146	67,40	
480 x 585	130	102	96	M 24	42	1000	512270	2134	181	148	71,00	
500 x 605	130	102	96	M 24	44	1000	559025	2236	182	150	72,60	
520 x 630	130	102	96	M 24	45	1000	603344	2321	179	148	80,00	
540 x 650	130	102	96	M 24	45	1000	626549	2321	172	143	82,00	
560 x 670	130	102	96	M 24	48	1000	683027	2439	177	148	85,00	
580 x 690	130	102	96	M 24	50	1000	736897	2541	178	150	88,00	
600 x 710	130	102	96	M 24	50	1000	773517	2578	172	145	91,00	

● Clamping sets available from stock.

1) The screw tightening torques can be increased by max. 1,1 times or reduced to 0,6 times of the aforementioned figures with T, F_{ax} and P_w, P_N being reduced proportionally.

Other sizes on request.

CLAMPEX® - Shaft-Hub-Connection

Not self-centering

KTR 150



- Clamping set for small radial mounting dimensions
- Increase of torque by using several clamping sets in a series
- Please find our detailed mounting instructions on our homepage (www.ktr.com)

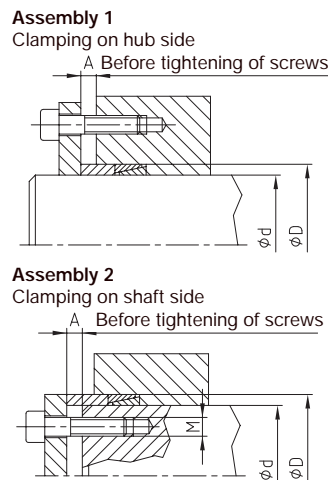
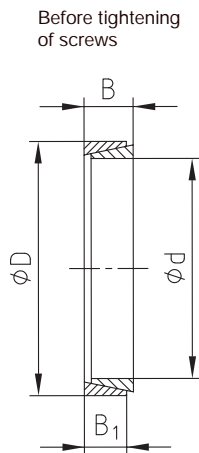

Up to 4 clamping sets can be used in a series.

The torques are increased as follows:

- 1 clamping element torque = torque_{catalogue} x 1
- 2 clamping elements torque = torque_{catalogue} x 1,55
- 3 clamping elements torque = torque_{catalogue} x 1,85
- 4 clamping elements torque = torque_{catalogue} x 2,02

Assembly

Clean and lightly oil the contact surfaces of shaft and hub. Insert the clamping element, distance ring and clamping flange, tighten the clamping screws crosswise by degrees and evenly until the screw tightening torque defined for the corresponding screw size is achieved. The figures T and F_{ax} mentioned in the table were calculated for an assembly with oil.

Note: Do not use any oil with molybdenum sulphide or high-pressure additions or grease reducing the coefficient of friction considerably. The clamping sets are delivered with oil. For assembly without oil the figures mentioned in the table deviate.

Disassembly

Unscrew all clamping screws. In normal cases the clamping element releases automatically. Otherwise lightly strike with a hammer onto the hub or shaft.

Tolerances, surfaces

One accurate turning process is sufficient:
R_z ≤ 6 µm

Maximum permissible tolerances:
Shaft h6 - hub H7 (up to Ø = 40 mm)
Shaft h8 - hub H8 (from Ø = 42 mm)

Recommended dimensions of pressure flange for 1 to 4 clamping elements KTR 150

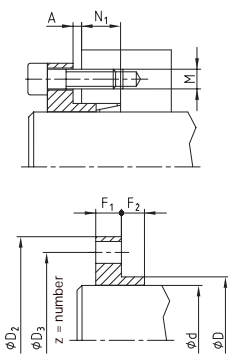

d ^{H8} x D _{g7}	9,1 x 12	10,1 x 13	12,1 x 15	13,1 x 16	14,1 x 18	15,1 x 19	16,2 x 20	17,2 x 21	18,2 x 22	19,2 x 24	20,2 x 25	22,2 x 26	24,2 x 28	25,2 x 30	28,2 x 32	30,2 x 35	32,2 x 36	35,2 x 40	36,2 x 42	38,2 x 44	40,2 x 45	42,2 x 48	45,2 x 52	48,2 x 55	50,2 x 57	55,2 x 62	56,2 x 64	60,2 x 68	63,2 x 71	65,2 x 73	70,2 x 79	71,2 x 80	75,2 x 84
D ₂	36	37	39	40	44	45	46	47	48	52	53	54	56	58	60	63	64	68	70	72	78	81	85	88	90	95	102	106	109	111	117	118	122
D ₃	28	29	31	32	35	36	37	38	39	42	43	44	45	48	50	53	54	58	60	62	65	68	72	75	77	82	86	90	93	95	101	102	106
M	M4	M4	M4	M4	M5	M5	M5	M5	M5	M6	M6	M6	M6	M6	M6	M6	M6	M6	M6	M6	M8	M8	M8	M8	M8	M8	M10	M10	M10	M10	M10	M10	M10
Z	4	4	4	4	4	4	4	4	4	4	4	4	4	4	4	4	5	6	6	6	4	4	6	8	8	8	6	6	6	6	8	8	8
Tightening torque [Nm]	2,9	2,9	2,9	2,9	6	6	6	6	6	10	10	10	10	10	10	10	10	10	10	10	25	25	25	25	25	25	49	49	49	49	49	49	49
F ₁	5,5	5,5	5,5	5,5	7	7	7	7	7	8	8	8	8	8	8	8	8	8	8	8	10,5	10,5	10,5	10,5	10,5	10,5	13	13	13	13	13	13	13
F ₂	7	7	7	7	8,5	8,5	8,5	8,5	8,5	8,5	8,5	8,5	8,5	8,5	8,5	8,5	8,5	8,5	8,5	8,5	9,5	9,5	9,5	9,5	9,5	9,5	10,5	10,5	10,5	10,5	10,5	10,5	10,5
N ₁	The hollow depth results from the number of clamping elements (max. 4-off) and the dimension = F ₂ - A																																

Orderform:

KTR 150	60	x	68
Type:	Size of inside diameter		Size of outside diameter

CLAMPEX® - Shaft-Hub-Connection

Technical data

KTR 150



Dimensions [mm]	Distance dimension A [mm]				Dimension of distance ring [mm]		Necessary clamping force for clamping screws $\mu_{total} = 0,14$			Transmittable torque or axial force		Surface pressure between clamping elements		Weight -kg	Stock pro- gramme		
	d x D	B	B ₁	1	2	3	4	d ₁ x D ₁	P _O [N]	P _S [N]	P _A = P _O + P _S [N]	T [Nm]	F _{ax} [kN]			Shaft P _w [N/mm ²]	Hub P _N [N/mm ²]
6 x 9	4,5	3,7	2,5	2,5	3,0	4,0	6,1	8,9	**	3000	3000	2	0,67	80	53	0,0012	●
7 x 10	4,5	3,7	2,5	2,5	3,0	4,0	7,1	9,9	**	5300	5300	4	1,19	121	85	0,0014	●
8 x 11	4,5	3,7	2,5	2,5	3,0	4,0	8,1	10,9	**	5600	5600	5	1,25	112	82	0,0015	●
9 x 12	4,5	3,7	2,5	2,5	3,0	4,0	9,1	11,9	7947	6653	14600	7	1,50	119	89	0,0017	●
10 x 13	4,5	3,7	2,5	2,5	3,0	4,0	10,1	12,9	7063	8937	16000	10	2,00	143	110	0,0018	●
12 x 15	4,5	3,7	2,5	2,5	3,0	4,0	12,1	14,9	7808	8192	16000	11	1,80	110	88	0,0021	●
13 x 16	4,5	3,7	2,5	2,5	3,0	4,0	13,1	15,9	7007	9693	16700	14	2,20	120	97	0,0023	●
14 x 18	6,3	5,3	3,5	3,5	4,5	5,5	14,1	17,9	11957	14043	26000	22	3,10	112	87	0,0049	●
15 x 19	6,3	5,3	3,5	3,5	4,5	5,5	15,1	18,9	12106	14894	27000	25	3,30	111	88	0,0053	●
16 x 20	6,3	5,3	3,5	3,5	4,5	5,5	16,1	19,9	12478	14522	27000	26	3,20	102	81	0,0055	●
17 x 21	6,3	5,3	3,5	3,5	4,5	5,5	17,1	20,9	11678	16822	28500	32	4,10	120	90	0,0058	●
18 x 22	6,3	5,3	3,5	3,5	4,5	5,5	18,1	21,9	14630	18370	33000	37	3,70	102	94	0,0061	●
19 x 24	6,3	5,3	3,5	3,5	4,5	5,5	19,2	23,8	14186	18814	33000	40	4,20	111	88	0,0078	●
20 x 25	6,3	5,3	3,5	3,5	4,5	5,5	20,2	24,8	13339	19661	33000	44	4,40	110	88	0,0082	●
22 x 26	6,3	5,3	3,5	3,5	4,5	5,5	22,2	25,8	13689	20311	34000	50	4,50	103	87	0,0072	●
24 x 28	6,3	5,3	3,5	3,5	4,5	5,5	24,2	27,8	8676	25324	34000	68	5,70	118	101	0,008	●
25 x 30	6,3	5,3	3,5	3,5	4,5	5,5	25,2	29,8	10190	26810	37000	75	6,00	120	100	0,010	●
28 x 32	6,3	5,3	3,5	3,5	4,5	5,5	28,2	31,8	11275	28725	40000	90	6,40	115	101	0,009	●
30 x 35	6,3	5,3	3,5	3,5	4,5	5,5	30,2	34,8	10211	29789	40000	100	6,70	111	95	0,012	●
32 x 36	6,3	5,3	3,5	3,5	4,5	5,5	32,2	35,8	6487	33513	40000	120	7,50	117	104	0,010	●
35 x 40	7	6	3,5	3,5	4,5	5,5	35,2	39,8	9147	40853	50000	160	9,10	115	101	0,017	●
36 x 42	7	6	3,5	3,5	4,5	5,5	36,2	41,8	12910	43690	56600	176	9,80	120	103	0,020	●
38 x 44	7	6	3,5	3,5	4,5	5,5	38,2	43,8	15317	44683	60000	190	10,00	116	100	0,021	●
40 x 45	8	6,6	3,5	4,5	5,5	6,5	40,2	44,8	18614	51386	70000	230	11,50	116	103	0,023	●
42 x 48	8	6,6	3,5	4,5	5,5	6,5	42,2	47,8	14678	55322	70000	260	12,40	118	104	0,028	●
45 x 52	10	8,6	3,5	4,5	5,5	6,5	45,2	51,8	32549	77451	110000	390	17,30	119	103	0,042	●
48 x 55	10	8,6	3,5	4,5	5,5	6,5	48,2	54,8	29942	80058	110000	430	17,90	115	100	0,045	●
50 x 57	10	8,6	3,5	4,5	5,5	6,5	50,2	56,8	25995	84005	110000	470	18,80	116	102	0,047	●
55 x 62	10	8,6	3,5	4,5	5,5	6,5	55,2	61,8	25759	94241	120000	580	21,10	118	105	0,050	●
56 x 64	12	10,4	3,5	4,5	5,5	7,0	56,2	63,8	33227	117773	151000	738	26,40	120	105	0,067	●
60 x 68	12	10,4	3,5	4,5	5,5	7,0	60,2	67,8	34887	125113	160000	840	28,00	119	105	0,072	●
63 x 71	12	10,4	3,5	4,5	5,5	7,0	63,2	70,8	30510	132490	163000	934	29,70	120	107	0,077	●
65 x 73	12	10,4	3,5	4,5	5,5	7,0	65,2	72,8	22513	137487	160000	1000	30,80	121	108	0,079	●
70 x 79	14	12,2	3,5	5,0	6,5	7,5	70,3	78,7	34033	165967	200000	1300	37,10	115	102	0,110	●
71 x 80	14	12,2	3,5	5,0	6,5	7,5	71,3	79,7	36043	174957	211000	1390	39,20	120	106	0,120	●
75 x 84	14	12,2	3,5	5,0	6,5	7,5	75,3	83,7	41267	178733	220000	1500	40,00	116	104	0,130	●
80 x 91	17	15	4,0	6,0	6,5	8,0	80,3	90,7	65412	234588	300000	2100	52,50	116	102	0,190	●
85 x 96	17	15	4,0	6,0	6,5	8,0	85,3	95,7	54414	257586	312000	2450	57,60	120	106	0,200	●
90 x 101	17	15	4,0	6,0	6,5	8,0	90,3	100,7	51900	268100	320000	2700	60,00	118	105	0,220	●
95 x 106	17	15	4,0	6,0	6,5	8,0	95,3	105,7	52145	287855	340000	3060	64,40	120	107	0,230	●
100 x 114	21	18,7	5,0	6,0	7,0	9,0	100,3	113,7	64660	375340	440000	4200	84,00	119	105	0,380	●
110 x 124	21	18,7	5,0	6,0	7,0	9,0	110,3	123,7	100658	349342	450000	4300	78,20	101	89	0,410	●
120 x 134	21	18,7	5,0	6,0	7,0	9,0	120,4	133,6	80192	379808	460000	5100	85,00	100	90	0,450	●
130 x 148	28	25,3	5,0	7,0	9,0	11,0	130,4	147,6	93177	556823	650000	8100	124,60	101	88	0,850	●
140 x 158	28	25,3	6,0	7,0	9,0	11,0	140,4	157,6	89967	600033	690000	9400	134,30	101	89	0,910	●
150 x 168	28	25,3	6,0	7,0	9,0	11,0	150,4	167,6	64644	655356	720000	11000	146,70	103	92	0,970	●
160 x 178	28	25,3	6,0	7,0	9,0	11,0	160,4	177,6	80303	774697	855000	13870	173,40	114	102	1,020	●
170 x 191	33	30	7,0	9,0	10,0	12,0	170,5	190,5	128166	973834	1102000	18525	217,90	113	101	1,500	●
180 x 201	33	30	7,0	9,0	10,0	12,0	180,5	200,5	142494	1057506	1200000	21300	236,70	116	104	1,580	●
190 x 211	33	30	7,0	9,0	10,0	12,0	190,5	210,5	111751	1138249	1250000	24200	254,70	119	107	1,680	●
200 x 224	38	34,8	7,0	9,0	11,0	13,0	200,6	223,4	182475	1407525	1590000	31500	315,00	120	107	2,320	●
210 x 234	38	34,8	7,0	9,0	11,0	13,0	210,6	233,4	100300	1489700	1590000	34761	331,10	121	109	2,450	●
220 x 244	38	34,8	7,0	9,0	11,0	13,0	220,6	243,4	117900	1552100	1670000	37941	344,90	120	109	2,490	●
230 x 257	43	39,5	7,0	10,0	12,0	14,0	230,6	256,4	168900	1851100	2020000	47307	411,90	121	108	3,380	●
240 x 267	43	39,5	7,0	10,0	12,0	14,0	240,6	266,4	160700	1929300	2090000	51449	428,70	121	109	3,520	●
250 x 280	48	44	7,0	10,0	12,0	16,0	250,6	279,2	191000	2239000	2430000	52245	418,00	121	108	4,680	●
260 x 290	48	44	7,0	10,0	13,0	16,0	260,8	289,2	182500	2328500	2511000	56506	434,70	121	108	4,820	●
270 x 300	48	44	7,0	10,0	13,0	16,0	270,8	299,2	178000	2422000	2600000	61036	452,10	121	109	4,940	●
280 x 313	53	49	7,0	11,0	14,0	17,0	280,8	312,2	207800	2792200	3000000	72971	521,20	121	108	6,270	●
290 x 323	53	49	7,0	11,0	14,0	17,0	290,8	322,2	220700	2889300	3110000	77740	536,10	121	108	6,500	●
300 x 333	53	49	7,0	11,0	14,0	17,0	300,8	332,2	215000	2990000	3205000	83224	554,80	121	109	6,700	●
320 x 360	65	59	10,0	15,0	20,0	25,0	321	359	292000	3848000	4140000	114246	714,00	121	108	10,900	●
340 x 380	65	59	10,0	15,0	20,0	25,0	341	379	275000	4085000	4360000	128863	758,00	121	108	11,500	●
360 x 400	65	59	10,0	15,0	20,0	25,0	361	399	260000	4320000	4580000	144292	801,60	121	109	12,200	●
380 x 420	65	59	10,0	15,0	20,0	25,0	381	419	270000	4570000	4840000	161122	848,00	121	109	12,800	●
400 x 440	65	59	10,0	15,0	20,0	25,0	401	439	260000	4800000	5060000	178138	890,70	121	110	13,500	●

● Clamping sets available from stock or in short term.

** Design with slot

Other sizes on request.

CLAMPEX® - Shaft-Hub-Connection

KTR 200

With torsionally flexible ROTEX® coupling

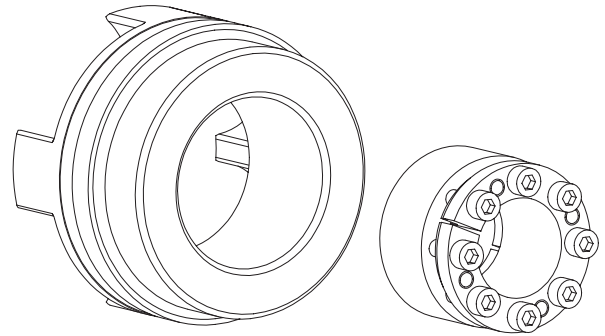
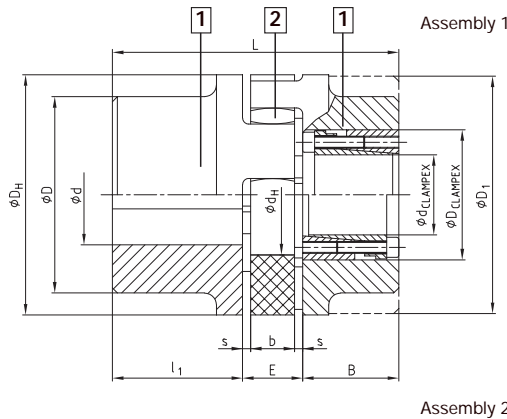

ROTEX® Size	Pilot bore ϕd	Hub material	CLAMPEX® KTR-200				Dimensions of ROTEX® coupling [mm]								
			Maximum KTR clamping $d \times D$	Transmittable torques and axial force		B	l_1	E	s	b	D_H	D	D_1	d_H	L
				T[Nm]	F_{ax} [kN]										
42	x		30 x 55	769	51	48	50	26	3	20	95		95	46	
48	x		35 x 60	1197	68	48	56	28	3,5	21	105		105	51	
55	x	Steel	45 x 75	2132	95	59	65	30	4	22	120		120	60	
65	x	part 1	45 x 75	2132	95	59	75	35	4,5	26	135	115		68	
75	x		50 x 80	3159	126	59	85	40	5	30	160	135		80	Length L > $l_1 + E + B$ (clamping set)
90	x		65 x 95	4107	126	59	100	45	5,5	34	200	160		100	
100	45		65 x 95	4107	126	59	110	50	6	38	225	180		113	
110	58		70 x 110	7023	201	70	120	55	6,5	42	255	200		127	
125	58	GGG 40	80 x 120	8026	201	70	140	60	7	46	290	230		147	
140	56	part 1	95 x 135	11373	239	66	155	65	7,5	50	320	255		165	
160	78		110 x 155	16068	292	80	175	75	9	57	370	290		190	
180	80		120 x 165	21910	365	80	195	85	10,5	64	420	325		220	

KTR 200 Size	Length	Transmittable torques and axial force		Clamping screws DIN 912-12.9		KTR 200 Size	Length	Transmittable torques and axial force		Clamping screws DIN 912-12.9		KTR 200 Size	Length	Transmittable torques and axial force		Clamping screws DIN 912-12.9	
		T[Nm]	F_{ax} [kN]	z x M	T_a [Nm]			T[Nm]	F_{ax} [kN]	z x M	T_a [Nm]			T[Nm]	F_{ax} [kN]	z x M	T_a [Nm]
20 x 47	48	513	51	6xM6	17	38 x 65	48	1299	68	8xM6	17	65 x 95	59	4107	126	8xM8	41
22 x 47	48	564	51	6xM6	17	40 x 65	48	1368	68	8xM6	17	70 x 110	70	7023	201	8xM10	83
24 x 50	48	616	51	6xM6	17	42 x 75	59	1990	95	6xM8	41	75 x 115	70	7524	201	8xM10	83
25 x 50	48	641	51	6xM6	17	45 x 75	59	2132	95	6xM8	41	80 x 120	70	8026	201	8xM10	83
28 x 55	48	718	51	6xM6	17	48 x 80	59	3033	126	8xM8	41	85 x 125	70	10659	251	10xM10	83
30 x 55	48	769	51	6xM6	17	50 x 80	59	3159	126	8xM8	41	90 x 130	70	11286	251	10xM10	83
32 x 60	48	1094	68	8xM6	17	55 x 85	59	3475	126	8xM8	41	95 x 135	66	11373	239	10xM10	83
35 x 60	48	1197	68	8xM6	17	60 x 90	59	3791	126	8xM8	41	Further details see page 219					

Other coupling combination

RADEX-N NANA 1 with external clamping set KTR 620 and KTR 603

KTR 620

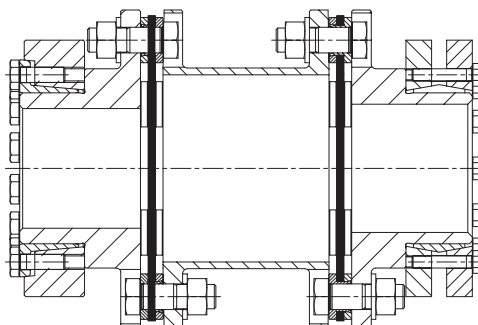

KTR 603

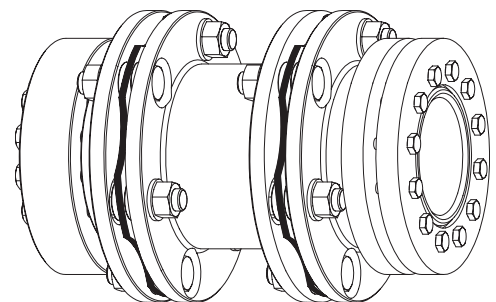

Further details about the external clamping set KTR 620 and KTR 603 are shown on page 210-215.

Series on request

SPH Clamping sleeve

Self-centering



- Fast assembly and disassembly with one screw only
- Suitable for hub dimensions
- Applications: sprockets, pulleys that are assembled to the shaft end

KTR 401

Self-centering, short design



- Clamping set for high load
- Specifically suitable for vibratory torques
- Typical applications: flywheels, belt drums
- Smaller dimensions than with KTR 400
- Please order our dimension sheet No. **M 367699**

KTR 125, KTR 125.1

KTR 125

Not self-centering,
Short design

KTR 125.1

Self-centering,
Long design



- Clamping set for applications with low demands
- Very easy assembly
- Please order our dimension sheet No. **M 367700**

KTR 700

Rigid coupling



- Rigid, backlash-free torque transmission
- Well-aligned, bending and torsionally stiff shaft connection
- Shaft misalignment cannot be compensated
- Please order our **dimension sheet No. M 367701**

Calculation

For a properly working CLAMPEX shaft-hub-connection the following technical details should be taken into account. Please contact us in case you have tolerances different from the table below.

Type	d [mm]	d _w [mm]	Shaft diameter tolerance	Diameter of hub bore tolerance	Surface roughness [µm]	Concentricity (applies for the clamping set only)
KTR 250	-	-	h8	H8	Rz ≤ 16	0,02 – 0,04
KTR 200	-	-	h8	H8	Rz ≤ 16	0,02 – 0,04
KTR 201	-	-	h8	H8	Rz ≤ 16	0,02 – 0,04
KTR 203	-	-	h8	H8	Rz ≤ 16	0,02 – 0,04
KTR 206	-	-	h8	H8	Rz ≤ 16	0,02 – 0,04
KTR 225	-	-	h8	H8	Rz ≤ 16	0,02 – 0,04
KTR 100	-	-	h11	H11	Rz ≤ 16	1)
KTR 105	-	-	h9	H9	Rz ≤ 16	0,02 – 0,04
KTR 150	up to 38	-	h6	H7	Rz ≤ 6	1)
KTR 150	bigger than 38	-	h8	H8	Rz ≤ 6	1)
KTR 400	-	-	h8	H8	Rz ≤ 16	0,02 – 0,04
KTR 620	-	13-145>150	H7/h6 > H7/g6	H7/f7	Rz ≤ 16	0,02 – 0,04
KTR 603	-	18 - 30	j6	H6	Rz ≤ 16	0,02 – 0,04
KTR 603	-	31 - 50	h6	H6	Rz ≤ 16	0,02 – 0,04
KTR 603	-	51 - 80	g6	H6	Rz ≤ 16	0,02 – 0,04
KTR 603	-	81 - 500	g6	H7	Rz ≤ 16	0,02 – 0,04

1) Depending on the centering of the hub or shafts or the drive component and accuracy of assembly, respectively.

Resulting torque T_R

The transmittable torque $T \approx T_R$ always has to exceed the highest torque peak T_B which may arise in the connection positions. The torque peaks arising during the acceleration of electric motors have to be considered.

$$T \approx T_R \geq \sqrt{T_B^2 + \left[\frac{F_a \cdot d}{2} \right]^2} \quad [\text{Nm}]$$

Transmittable axial force F_{ax}

The maximum transmittable axial force F_{ax} which is mentioned in the tables has to be reduced accordingly in case of additional torque transmission.

$$F_{ax} = \frac{2 \cdot T}{d} \quad [\text{KN}]$$

Calculation of the outside diameter of the hub D_N

The required outside diameter of the hub D_N depends on the cross section of the hub, the shape of the hub and the apparent yield point of the hub material. In order to facilitate the calculation the table on page 235 shows some figures by the help of which D_N can be determined.

Example:

Shaft diameter $d = 50 \text{ mm}$
 Hub material: GGG 40
 Apparent yield point of material $\sigma_{0,2} = 250 \text{ N/mm}$

Selected: CLAMPEX® clamping set KTR 100

with $d \times D = 50 \text{ mm} \times 80 \text{ mm}$ and $p_N = 149 \text{ N/mm}^2$ page 229
 \Rightarrow approximate value from table on page 235: $p_N = 150 \text{ N/mm}^2$
 selected design see page 235. $C = 0,6$ (value C of hub shape)
 \Rightarrow figure as per table 1,46
 $\Rightarrow D_N = D \times 1,46 = 80 \text{ mm} \times 1,46 = 116,8 \text{ mm}$

Outside diameters of hubs which cannot be calculated based on the table are calculated with the following formula:

$$D_N \geq d \cdot \sqrt{\frac{\sigma_{N0,2} + p_N \cdot C}{\sigma_{N0,2} - p_N \cdot C}} \quad [\text{mm}]$$

Tangential tension on the inside diameter of hub

$$\sigma_{tH} \approx p_N \cdot \frac{(1 + C_N^2)}{(1 - C_N^2)} \cdot C \quad [\text{N/mm}^2]$$

For clamping connections with hollow shafts the required inside diameter of the hollow shaft d_{iW} is calculated with the following formula:

$$d_{iW} \leq d \cdot \sqrt{\frac{\sigma_{W0,2} - 2 \cdot p_W \cdot 0,8}{\sigma_{W0,2}}} \quad [\text{mm}]$$

Tangential tension on the inside diameter of shaft

$$\sigma_{tW} \approx \frac{2 \cdot p_W}{(C_W^2 - 1)} \quad [\text{N/mm}^2]$$

$\sigma_{N0,2}$ = Apparent yield point of the hub material [N/mm²]
 C = Value C of hub shape (see picture on page 235)
 p_N = Perm. surface pressure of clamping set/hub [N/mm²]
 D = Outside diameter of the clamping set [mm]
 T = Transmittable torque [Nm]
 T_R = Resulting transmittable torque [Nm]
 T_B = Operating torque to be transmitted [Nm]
 L/L₁ = Hub length [mm]

$\sigma_{W0,2}$ = Apparent yield point of the shaft material [N/mm²]
 p_W = Perm. surface pressure of clamping set/shaft [N/mm²]
 d = Inside diameter of the clamping set [mm]
 C_W = d_{iW} / d
 C_N = D / D_N
 F_a = Axial force arising during operation [N]
 F_{ax} = Maximum transmittable axial force [N]
 F_V = Prestressed force [N]

Calculation of hubs

Table of screws

Dimension M	Prestressed force F_v and tightening torque T_a with $\mu_{total} = 0,14$					
	Prestressed force F_v [N]			Tightening torque T_a [Nm]		
	8,8	10,9	12,9	8,8	10,9	12,9
M 3	2210	3110	3730	1,34	1,89	2,25
M 4	3900	5450	6550	2,9	4,1	4,9
M 5	6350	8950	10700	6	8,5	10
M 6	9000	12600	15100	10	14	17
M 8	16500	23200	27900	25	35	41
M 10	26200	36900	44300	49	69	83
M 12	38300	54000	64500	86	120	145
M 14	52500	74000	88500	135	190	230
M 16	73000	102000	123000	210	295	355
M 18	88000	124000	148000	290	405	485
M 20	114000	160000	192000	410	580	690
M 22	141000	199000	239000	550	780	930
M 24	164000	230000	276000	710	1000	1200
M 27	215000	302000	363000	1050	1500	1800
M 30	262000	368000	442000	1450	2000	2400

Mounting conditions of clamping set

Value C of hub shape

C = 0,6

C = 0,8

C = 1

L/L_1 = Hub length
 B_2/B_3 = Clamping set length

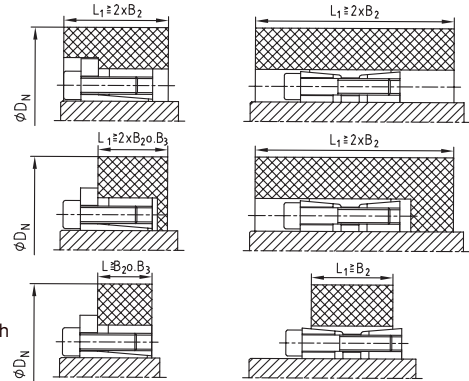

Selection table for the calculation of the required outside diameter of hub DN

Surface pressure between clamping set and hub p_N N/mm ²		Average apparent yield point of material σ 0,2 in N/mm ² (more accurate stiffness data, depending on the diameter, as per details mentioned by the manufacturer)										
		150	180	200	220	250	270	300	350	400	450	600
Hub form C-value		Hub materials										Tempering steel
		GG 20	GG 25 GS 38	GG 30 GTS 35	GS 45 ST 37-2	GGG 40 GS 52 AlCu MgPb	ST 50-2 C 35	GGG 50 GS 60 ST 52-3	GGG 60 GS 62 C 45	GGG 70 GS 70 C 60		
60	C = 0,6	1,28	1,25	1,20	1,18	1,15	1,14	1,12	1,10	1,09	1,08	1,06
	C = 0,8	1,39	1,30	1,24	1,23	1,22	1,20	1,18	1,15	1,12	1,11	1,08
	C = 1	1,52	1,42	1,36	1,32	1,28	1,25	1,22	1,18	1,16	1,14	1,10
65	C = 0,6	1,30	1,25	1,22	1,20	1,18	1,15	1,13	1,11	1,10	1,09	1,07
	C = 0,8	1,44	1,35	1,30	1,28	1,24	1,22	1,20	1,16	1,14	1,12	1,09
	C = 1	1,60	1,45	1,40	1,35	1,30	1,28	1,24	1,20	1,18	1,16	1,12
70	C = 0,6	1,34	1,26	1,24	1,22	1,18	1,16	1,15	1,12	1,11	1,10	1,07
	C = 0,8	1,48	1,38	1,34	1,30	1,25	1,23	1,20	1,18	1,15	1,13	1,10
	C = 1	1,65	1,50	1,45	1,40	1,34	1,30	1,26	1,22	1,20	1,17	1,13
75	C = 0,6	1,30	1,28	1,25	1,23	1,20	1,18	1,16	1,14	1,12	1,11	1,08
	C = 0,8	1,52	1,42	1,36	1,32	1,28	1,25	1,22	1,18	1,16	1,14	1,11
	C = 1	1,74	1,55	1,48	1,42	1,36	1,33	1,30	1,25	1,20	1,18	1,13
80	C = 0,6	1,39	1,31	1,28	1,25	1,21	1,20	1,18	1,15	1,13	1,11	1,08
	C = 0,8	1,58	1,45	1,39	1,35	1,30	1,27	1,24	1,20	1,18	1,15	1,11
	C = 1	1,81	1,61	1,53	1,46	1,39	1,36	1,31	1,26	1,22	1,20	1,14
85	C = 0,6	1,42	1,34	1,30	1,27	1,23	1,21	1,19	1,16	1,14	1,12	1,09
	C = 0,8	1,63	1,49	1,42	1,38	1,32	1,29	1,26	1,22	1,19	1,16	1,12
	C = 1	1,90	1,67	1,57	1,50	1,42	1,39	1,34	1,28	1,24	1,21	1,15
90	C = 0,6	1,46	1,36	1,32	1,28	1,25	1,22	1,20	1,17	1,15	1,13	1,09
	C = 0,8	1,69	1,53	1,46	1,40	1,34	1,31	1,28	1,23	1,20	1,18	1,13
	C = 1	2,00	1,73	1,62	1,54	1,46	1,41	1,36	1,30	1,26	1,22	1,16
95	C = 0,6	1,49	1,39	1,34	1,30	1,26	1,24	1,21	1,18	1,15	1,14	1,10
	C = 0,8	1,75	1,57	1,49	1,43	1,37	1,34	1,30	1,25	1,21	1,19	1,14
	C = 1	2,11	1,80	1,69	1,59	1,49	1,44	1,39	1,32	1,27	1,24	1,17
100	C = 0,6	1,53	1,41	1,36	1,32	1,28	1,25	1,22	1,19	1,16	1,14	1,11
	C = 0,8	1,81	1,61	1,53	1,46	1,39	1,36	1,31	1,26	1,22	1,20	1,14
	C = 1	2,24	1,87	1,73	1,63	1,53	1,48	1,41	1,34	1,29	1,25	1,18
105	C = 0,6	1,56	1,44	1,39	1,34	1,29	1,27	1,24	1,20	1,17	1,15	1,11
	C = 0,8	1,88	1,66	1,56	1,50	1,42	1,38	1,33	1,28	1,24	1,21	1,15
	C = 1	2,38	1,95	1,79	1,68	1,56	1,51	1,44	1,36	1,31	1,27	1,19
110	C = 0,6	1,60	1,47	1,41	1,36	1,31	1,28	1,25	1,21	1,18	1,16	1,12
	C = 0,8	1,96	1,71	1,60	1,53	1,44	1,40	1,35	1,29	1,25	1,22	1,16
	C = 1	2,55	2,04	1,86	1,73	1,60	1,54	1,47	1,38	1,33	1,28	1,20
115	C = 0,6	1,64	1,50	1,43	1,36	1,33	1,30	1,26	1,22	1,19	1,17	1,12
	C = 0,8	2,04	1,76	1,64	1,56	1,47	1,43	1,37	1,31	1,26	1,23	1,17
	C = 1	2,75	2,13	1,93	1,79	1,64	1,58	1,50	1,41	1,34	1,30	1,21
120	C = 0,6	1,69	1,53	1,46	1,40	1,34	1,31	1,28	1,23	1,20	1,18	1,13
	C = 0,8	2,13	1,81	1,69	1,60	1,50	1,45	1,39	1,33	1,28	1,24	1,18
	C = 1	3,00	2,24	2,00	1,84	1,69	1,61	1,53	1,43	1,36	1,31	1,22
125	C = 0,6	1,73	1,56	1,48	1,43	1,36	1,33	1,29	1,24	1,21	1,18	1,13
	C = 0,8	2,24	1,87	1,73	1,63	1,53	1,48	1,41	1,34	1,29	1,25	1,18
	C = 1	3,32	2,35	2,08	1,91	1,73	1,65	1,56	1,45	1,38	1,33	1,24
130	C = 0,6	1,78	1,59	1,51	1,45	1,38	1,35	1,30	1,25	1,22	1,19	1,14
	C = 0,8	2,35	1,93	1,78	1,67	1,56	1,50	1,44	1,36	1,30	1,27	1,19
	C = 1	3,74	2,49	2,17	1,97	1,78	1,69	1,59	1,48	1,40	1,35	1,25
135	C = 0,6	1,83	1,62	1,54	1,47	1,40	1,36	1,32	1,27	1,23	1,20	1,15
	C = 0,8	2,48	2,00	1,83	1,71	1,59	1,53	1,46	1,38	1,32	1,28	1,20
	C = 1	4,36	2,65	2,27	2,04	1,83	1,73	1,62	1,50	1,42	1,36	1,26
140	C = 0,6	1,88	1,66	1,56	1,50	1,42	1,38	1,33	1,28	1,24	1,21	1,15
	C = 0,8	2,63	2,07	1,88	1,75	1,62	1,55	1,48	1,39	1,33	1,29	1,21
	C = 1	5,39	2,83	2,38	2,12	1,88	1,78	1,66	1,53	1,44	1,38	1,27
145	C = 0,6	1,94	1,69	1,59	1,52	1,44	1,40	1,35	1,29	1,25	1,22	1,16
	C = 0,8	2,80	2,15	1,94	1,80	1,65	1,58	1,50	1,41	1,35	1,30	1,22
	C = 1	7,68	3,05	2,50	2,21	1,94	1,82	1,69	1,55	1,46	1,40	1,28
150	C = 0,6	2,00	1,73	1,62	1,54	1,46	1,41	1,36	1,30	1,26	1,23	1,16
	C = 0,8	3,00	2,24	2,00	1,84	1,69	1,61	1,53	1,43	1,36	1,31	1,23
	C = 1	-	3,32	2,65	2,30	2,00	1,87	1,73	1,58	1,48	1,41	1,29
155	C = 0,6	2,06	1,77	1,65	1,57	1,48	1,43	1,38	1,31	1,27	1,24	1,17
	C = 0,8	3,25	2,33	2,06	1,89	1,72	1,65	1,55	1,45	1,38	1,33	1,23
	C = 1	-	3,66	2,80	2,40	2,06	1,92	1,77	1,61	1,51	1,43	1,30
160	C = 0,6	2,13	1,81	1,69	1,60	1,50	1,45	1,39	1,33	1,28	1,24	1,18
	C = 0,8	3,55	2,43	2,13	1,94	1,76	1,67	1,58	1,47	1,39	1,34	1,24
	C = 1	-	4,12	3,00	2,52	2,13	1,98	1,81	1,64	1,53	1,45	1,31
165	C = 0,6	2,21	1,86	1,72	1,62	1,52	1,47	1,41	1,34	1,29	1,25	1,18
	C = 0,8	3,96	2,55	2,21	2,00	1,80	1,71	1,60	1,49	1,41	1,35	1,25
	C = 1	-	4,80	3,23	2,65	2,21	2,04	1,86	1,67	1,55	1,47	1,33



Quality Approval

Development
Partnership



Research
Service

www.ktr.com



INDUSTRIE FORUM
DESIGN HANNOVER